



1921 Bellamah NW
Albuquerque, NM 87104
t. 505.243.9889
f. 505.243.8197
www.cssabq.com

email us @
esr@cssabq.com

FOR YOUR INFORMATION

CONVENTION SERVICES OF THE SOUTHWEST. INC.

2025 SWTA ANNUAL TRANSIT CONFERENCE & EXPO
Tucson Convention Center
Tucson, Arizona
Wednesday, February 19 – Thursday, February 20, 2025

Dear Exhibitor:

WELCOME! CSS is pleased to be selected by show management to serve as your Official Service Contractor.

This Exhibitor Service Kit will assist you in planning for the show. In addition to important show information, we have included the necessary show service order forms. To help save you money, we have provided you with the opportunity to take advantage of advance order discounts.

When placing your order, please keep in mind:

- [On-Line Ordering](#) is available. Log-in information will be automatically emailed to the address on file with the association at the time of registration. If you do not receive the log-in, or are not the registered contact, please contact us at esr@cssabq.com or (505) 243-9889 to obtain one.
- Complete and return all order forms by the indicated discounted deadline date to avoid higher costs. Each form should be returned to the appropriate company and address listed on that form.
- Review our payment policy carefully. **CSS** requires payment in full at the time you place your order, along with a completed Credit Card Authorization form.
- Please include the prevailing sales tax in your order, **currently 8.7% in Tucson, Arizona**. Sales tax is applicable to rentals. Labor and material handling services are exempt in the state of Arizona. *(If you have a state or federal exemption, please include forms at the time of ordering.)*

We will help you coordinate all your trade show needs including the shipment of all your trade show materials. For your inbound and outbound freight shipments, we offer the service of our preferred carrier **ArcBest (ABF Freight) 1-800-654-7019**.

We look forward to serving you from start to finish. We are here to make sure your experience is a complete success. If you need assistance or additional information, please contact our Exhibitor Service Department:

Email: esr@cssabq.com
1921 Bellamah Ave. NW
Albuquerque, NM 87104
Phone: (505) 243-9889
Fax: (505) 243-8197

Or visit us on the World Wide Web at <http://www.cssabq.com>.



1921 Bellamah NW
 Albuquerque, NM 87104
 t. 505.243.9889
 f. 505.243.8197
 www.cssabq.com

email us @
 esr@cssabq.com

SHOW INFORMATION QUICK REFERENCE

CONVENTION SERVICES OF THE SOUTHWEST, INC.

SHOW NAME:	2025 SWTA Annual Transit Conference & Expo	
VEHICLE MOVE-IN:	Tuesday, February 18, 2025	2:00PM – 5:00PM
EXHIBITOR MOVE-IN:	Wednesday, February 19, 2025	8:00AM – 3:00PM
SHOW DATE(S):	Wednesday, February 19, 2025	4:00PM – 6:00PM (Reception)
	Thursday, February 20, 2025	12:00PM – 2:00PM (Luncheon)
VEHICLE MOVE-OUT:	Thursday, February 20, 2025	2:00PM – 6:00PM
EXHIBITOR MOVE-OUT:	Thursday, February 20, 2025	2:00PM – 6:00PM

Outside freight carriers must be checked in by: **Thursday, February 20, 2025 @ 5:00PM**
 All materials must be packed with bill(s) of lading turned in to **CSS** by: **Thursday, February 20, 2025 @ 6:00PM**

SHOW LOCATION: Tucson Convention Center
 Exhibit Halls B&C
 260 S Church Ave
 Tucson, AZ 85701

STANDARD BOOTH PACKAGE:	10' x 10'	
(Included with booth purchase)	8' Gold Draped Back Wall	
	3' Gold Draped Side Rail	
	(1) 6' Blue Draped Table	The exhibit hall IS NOT carpeted.
	(2) Molded Plastic Chairs	
	(1) Waste Basket w/ Liner	Aisle Carpet color is Tuxedo .
	(1) 7" x 44" ID Sign	

NOTE: The Tucson Convention Center REQUIRES advanced notice of motorized vehicles on display, and EACH VEHICLE must have a temporary permit posted on the dashboard declaring compliance with the Tucson Fire Code.

IMPORTANT DEADLINES:

First date freight can arrive at the advance warehouse:	Tuesday, January 21, 2025
Submission deadline for exhibitor appointed contractor (EAC) notification:	Tuesday, January 21, 2025
Last date to receive certificate of insurance for EAC:	Tuesday, January 21, 2025
Advance Orders and Payment Deadline:	Monday, February 03, 2025
Last date freight can arrive at the advance warehouse:	Friday, February 14, 2025
First date for direct shipments to facility:	Tuesday, February 18, 2025

NOTE: CSS will be closed on Monday, January 20, 2025.

SHIPPING INFORMATION:

ADVANCE FREIGHT RECEIVING

Monday – Friday 8:00AM – 5:00PM

Tuesday, January 21 – Friday, February 14, 2025

ADVANCE SHIPPING ADDRESS

Ship To: Exhibitor Name and Booth #
SWTA 2025
 c/o **CSS**
 ABF Freight
 2943 E Wieding Road
 Tucson, AZ 85706

DIRECT FREIGHT RECEIVING

Tuesday, February 18, 2025 --- 8:00AM – 5:00PM

Wednesday, Feb. 19, 2025 --- 8:00AM – 12:00PM

DIRECT SHIPPING ADDRESS

Ship To: Exhibitor Name and Booth #
 c/o **CSS**
SWTA 2025
 Tucson Convention Center – Exhibit Halls B&C
 260 S Church Ave.
 Tucson, AZ 85701



1921 Bellamah NW
Albuquerque, NM 87104
t. 505.243.9889
f. 505.243.8197
www.cssabq.com

email us @
esr@cssabq.com

CREDIT CARD AUTHORIZATION ORDER SUMMARY FORM TERMS AND CONDITIONS ACCEPTANCE

CONVENTION SERVICES OF THE SOUTHWEST, INC.

Event Name: SWTA 2025	Advance Payment Deadline: Monday, February 3, 2025	Booth # (s):
Company Name:	Telephone #:	
Billing Address:	Fax #:	
City/State/Zip:	Email Address:	
Authorized by:		

CREDIT CARD CHARGE AUTHORIZATION

For your payment security, we recommend that you log in to your account in our online ordering portal to authorize and process your order.

If you are unable to process your payment through our portal, you can complete the information requested below and return this form with your order(s). Any show site balances or charges for outbound labor, freight or miscellaneous items not paid before show closing will be charged to your credit card account. Your signature below acknowledges understanding and acceptance of the terms detailed in the **CSS** Payment Policy, the **CSS** Material Handling Information and Limits of Liability, and the **CSS** Conditions and Regulations for electrical usage provided with your Service Kit. Acceptance of **CSS**' payment policy, material handling terms and conditions, and limits of liability will be construed when any of the following conditions are met: This Credit Card Authorization is signed, the Material Handling Agreement (MHA) is signed; Exhibitor's materials are delivered to **CSS**'s warehouse or to an event site for which **CSS** is the Official Show Contractor; or an order for labor and/or rental equipment is placed by Exhibitor with **CSS**. **The Estimated Total below may not necessarily reflect the final total charged to your credit card at close of show.** (There will be a \$75.00 administrative fee if a credit card dispute is filed, and **CSS** is awarded charges.)

Last 4 of Credit Card #: Expiration Date: Billing Zip Code:

You will need to call CSS to provide your complete credit card number and card verification # to adhere to PCI Compliance Standards.

Cardholder Signature
Cardholder Name (please print)

CSS ORDER FORMS	AMOUNT DUE
Furnishings	
Upgrade Furnishings	
Carpet	
Prestige Carpet	
Rental Display	
Labor	
Material Handling	
Cleaning	
Sign/Graphics	
<i>Information included but ordered elsewhere</i>	
Electrical	XXXXXXXX
Phone/Internet	XXXXXXXX
AV	XXXXXXXX
Estimated Total (includes State Tax where applicable)	

Using the order forms, remember to include and transfer the sales tax into the estimated grand total above.
This form is intended as a tool to assist you and is not a replacement for any other form.



1921 Bellamah NW
Albuquerque, NM 87104
t. 505.243.9889
f. 505.243.8197
www.cssabq.com

email us @
esr@cssabq.com

PAYMENT POLICY

CONVENTION SERVICES OF THE SOUTHWEST, INC.

ADVANCE PRICING

To obtain the advance pricing, full payment must be included with your order. Orders received after the advance payment deadline date or made at the Exhibitor Service Center during the show, will be billed at the "Standard Price" as listed on the enclosed forms. **Telephone orders will not be accepted.**

PAYMENT OPTIONS

We offer two convenient ways for you to order and pay for your show services provided by **CSS**.

1. Service Kit (pdf download)
 - a. Advance payment by **Company Check, Wire Transfer, or e-check**: All checks for show services provided by **CSS** should be made payable to **Convention Services of the Southwest, Inc. (CSS)** and must be in U.S. Dollars drawn on a U.S. bank. International exhibitors must prepay all balances no later than the advanced payment deadline in U.S. Dollars drawn on U.S. banks. A **Credit Card Authorization** form is also required to cover any variances with regards to drayage (material handling) and labor orders as well as any additional charges incurred at show site.
 - i. Please note that for Wire Transfer/ACH payments, **CSS** does not pay bank fees from the sending or receiving bank. Please add \$25.00 to amounts transferred to be considered paid in full.
 - ii. **CSS** will add a fee of \$35.00 to any order where the check payment is returned as insufficient funds.
 - b. **Credit Card**: For your convenience we accept Visa, MasterCard, and American Express. You must complete the **Credit Card Authorization** form. For discount rates to apply, **CSS** must receive this form by **Monday, February 3, 2025**. *(There will be a \$75.00 administrative fee if a credit card dispute is filed and CSS is awarded charges.)*
2. **On-Line Ordering**
 - a. Log-in information with a temporary password will be automatically emailed to the email address on file with the association at the time of registration. To place your order, log-in and follow the instructions. A credit card on file is required to complete your order. An email will be sent confirming your order is complete. The charges on your confirmation will not be considered final until the show closes *(drayage fees are added once freight is received and floor orders may be added)*.

PAYMENT TERMS

To process your order for services and materials listed in this Exhibitor Service Kit, we must have your completed and signed Credit Card Authorization form or full payment in advance or you must place your order on-line. Invoices for outstanding balances will be emailed to the email address on file and must be paid before the end of the event. If you have any concerns about your charges, please stop by the Exhibitor Service Center at the show. **Charges may not be disputed after the show.**

Items ordered and delivered but subsequently canceled will be charged 50% of the order price to cover labor involved.

Please notify your company representative who will be at the show site of our payment policy. Your cooperation is appreciated. No credits will be issued after close of show.

If a display house represents the exhibiting company, the exhibiting company is ultimately responsible for payment of all costs incurred on its behalf. (See **Third Party Payment Form**). **Third Parties must contact CSS for an on-line log in.**



1921 Bellamah NW
 Albuquerque, NM 87104
 t. 505.243.9889
 f. 505.243.8197
 www.cssabq.com

email us @
 esr@cssabq.com

THIRD PARTY PAYMENT FORM

CONVENTION SERVICES OF THE SOUTHWEST. INC.

CSS will present show site invoices to third parties for payment of services rendered to exhibitors, provided the following conditions are met:

- The payment record of the third party is acceptable to **CSS**.
- This completed form is to be signed by **BOTH PARTIES** and returned to **CSS** by **Monday, February 3, 2025**.
- This form is to be accompanied by a completed **Credit Card Authorization** form from **EACH PARTY**.
- If there is any doubt which party is to be invoiced for a service, **the exhibiting firm accepts responsibility for payment upon presentation of invoice at show site**.
- The **exhibiting firm** is ultimately responsible for payment of all charges by show close.

Please indicate below which items/services are to be invoiced to the third party:

Furniture/Carpet
 Booth Cleaning
 Material Handling
 Booth Labor

Other:

WE UNDERSTAND AND AGREE THAT WE, THE EXHIBITING COMPANY, ARE ULTIMATELY RESPONSIBLE FOR PAYMENT OF CHARGES INCURRED. IN THE EVENT THE NAMED THIRD PARTY DOES NOT MAKE PAYMENT UPON PRESENTATION OF INVOICE AT SHOW SITE, SUCH CHARGES WILL BE PRESENTED TO THE EXHIBITING COMPANY FOR PAYMENT BEFORE THE CLOSE OF THE SHOW.

Event Name: SWTA 2025	Booth #:
Exhibiting Company:	Display House 3rd Party:
Address:	Address:
City/State/Zip:	City/State/Zip:
Telephone #:	Telephone #:
Fax #:	Fax #:
Email address:	Email address:
Authorized Signature:	Authorized Signature:
Print Name & Title:	Print Name & Title:



1921 Bellamah NW
 Albuquerque, NM 87104
 t. 505.243.9889
 f. 505.243.8197
 www.cssabq.com

email us @
 esr@cssabq.com

FURNISHINGS ORDER FORM

CONVENTION SERVICES OF THE SOUTHWEST, INC.

Event Name: SWTA 2025	Advance Payment Deadline: Monday, February 3, 2025	Booth # (s):
Company Name:	Telephone #:	
Billing Address:	Fax #:	
City/State/Zip:	Email Address:	
Authorized by:		

DRAPED DISPLAY TABLES - 30" HIGH (choose skirt color below)

Quantity	Description	Advance Price	Standard Price
	4'L X 30"H Draped Table	164	196
	6'L X 30"H Draped Table	184	220
	8'L X 30"H Draped Table	214	257

DRAPED DISPLAY COUNTERS - 40" HIGH (choose skirt color below)

	4'L X 40"H Draped Counter	187	224
	6'L X 40"H Draped Counter	225	270
	8'L X 40"H Draped Counter	246	295
	30"D X 40"H Spandex Round Highboy	211	253

UNDRAPED DISPLAY TABLES - 30" HIGH

	4'L X 30"H Undraped Table	94	113
	6'L X 30"H Undraped Table	108	129
	8'L X 30"H Undraped Table	137	164
	30"H Conference Table (circle choice) 36"D Black 36" D White 40"D Grey	295	354

UNDRAPED DISPLAY COUNTERS - 40" HIGH

	4'L X 40"H Undraped Counter	108	129
	6'L X 40"H Undraped Counter	125	150
	8'L X 40"H Undraped Counter	143	172
	40"H Conference Counter (circle choice) 36"D Black 36" D White 40"D Grey	316	378

TABLE SKIRTING (choose skirt color below)

	4th Side Table Drape for Table 30"H	92	111
	4th Side Table Drape for Counter 40"H	108	130
	Individual Table Skirt for Table 30"H	111	133
	Individual Table Skirt for Counter 40"H	128	154

SPECIAL DRAPERY (6' minimum) (choose drape color below)

	3' High Drapery/linear ft.	14	18
	8' High Drapery/linear ft.	24	28
	3' Upright w/ 1/2 Base	26	30
	8' Upright w/ Full Base	27	32
	Crossbar	27	32

STANDARD FURNITURE AND ACCESSORIES

	Grey Molded Plastic Chair	72	84
	Padded Side Chair	96	113
	Padded Arm Chair	105	122
	Upholstered Bar Stool with Back	118	138
	Bag Rack (circle choice) "T" waterfall	94	106
	Literature Rack (circle choice) flat accordion	223	249
	Aluminum Easel	44	49
	Wastebasket with Liner	30	34
	Fishbowl	42	47
	4' x 8' Board* Peg Board or Poster Board (circle choices) Horizontal or Vertical	204	245
	36" x 48" Double Sided Magnetic Whiteboard	204	245
	4'L X 7"H Table Riser (draped in vinyl)	79	95
	6'L X 7"H Table Riser (draped in vinyl)	103	110
	Glass Show Case (48"W x 18"D x 38"H w/lock and light)	443	Contact for Quote

*Maximum load on boards is 50 lbs. Poster Boards are black & Velcro/push pin "friendly".

SKIRT AND DRAPE COLOR CHOICES (please circle choice)

Blue Gold Teal Beige Hunter Green
 Black White Peach Burgundy Terra-Cotta
 Red Silver Plum Willow

SPANDEX COLOR CHOICES (please circle choice)

Red Black Blue
 White Teal Silver

PLEASE READ PAYMENT POLICY

SUBTOTAL	\$
Tax (8.7%)	\$
TOTAL	\$



1921 Bellamah NW
 Albuquerque, NM 87104
 t. 505.243.9889
 f. 505.243.8197
 www.cssabq.com

email us @
 esr@cssabq.com

STANDARD FURNISHINGS

CONVENTION SERVICES OF THE SOUTHWEST, INC.



DRAPED TABLE
 2' W X (4', 6', OR 8' L) X 30" H



DRAPED COUNTER
 2' W X (4', 6', OR 8' L) X 40" H



UNDRAPED TABLE/COUNTER
 2' W X (4', 6', OR 8' L) X 30" H OR 40" H



SPANDEX HIGHBOY
 30" D X 40" H



ROUND CONFERENCE TABLE/COUNTER
 36" D (BLACK/WHITE) or
 40" D (GREY) x 30" or 40" H

DRAPE COLORS

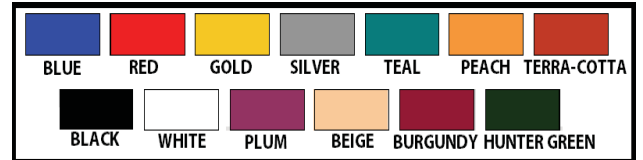

SPANDEX COLORS

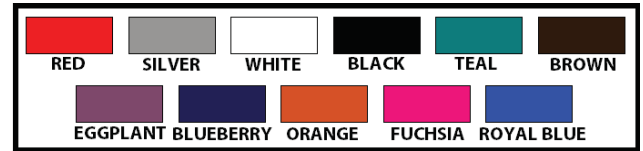

MOLDED PLASTIC CHAIR



PADDED SIDE CHAIR



PADDED ARM CHAIR



UPHOLSTERED BAR STOOL



1921 Bellamah NW
Albuquerque, NM 87104
t. 505.243.9889
f. 505.243.8197
www.cssabq.com

email us @
esr@cssabq.com

STANDARD FURNISHINGS

CONVENTION SERVICES OF THE SOUTHWEST, INC.



T STYLE BAG RACK
50" H X 15" W X 12" L



WATERFALL BAG RACK
50" H X 15" W X 12" L



ALUMINUM EASEL
64" H X 32" W X 32" L



FLAT LITERATURE STAND WITH 6
POCKETS
55" H X 14" W X 9" L



ACCORDION LITERATURE
STAND
5' HIGH

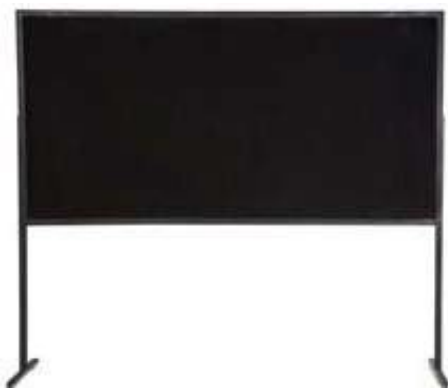

POSTER BOARD
(HORIZONTAL)
4' X 8'



WHITEBOARD (VERTICAL)
36"W X 48"H + FRAME



GLASS SHOW CASE
38" H X 48" W X 18" D



1921 Bellamah NW
Albuquerque, NM 87104
t. 505.243.9889
f. 505.243.8197
www.cssabq.com

email us @
esr@cssabq.com

UPGRADE FURNISHINGS ORDER FORM

CONVENTION SERVICES OF THE SOUTHWEST, INC.

Event Name: SWTA 2025	Advance Payment Deadline: Monday, February 3, 2025	Booth # (s):
Company Name:	Telephone #:	
Billing Address:	Fax #:	
City/State/Zip:	Email Address:	
Authorized by:		

Note: Due to limited quantities on many items, a comparable product may be substituted.
Please contact **CSS** for quantity availabilities.

UPGRADE CHAIRS

Quantity	Description	Dimensions	Color (please circle)	Price
	Jetson Chair	15" x 15" w/ adjustable seat	White Black	195
	Leather Office Chair w/ Mesh Back	34.7"H x 22.75"W x 24"D	Black Only	162
	Mesh Steno Chair w/ Wheels	38.5-42.2"H x 27.1"W x 26.7"D	Black Only	195
	Modern Chair	33.5"H x 18.8"W x 18.8"D	White Only	162
	Soda Fountain Barstool	30"H x 17"W x 17"D	Red Black	162
	Swivel Barstools w/ Curved Back	32.5"H x 22.5"W x 18"D	White Black	227

UPGRADE TABLES

	24" Bistro Table	23.75" - 42"H x 24"W x 24"D	White Black	259
	31" Glass Table	29"H x 31.5"W x 31.5"D		290
	Glass End Table	15"H x 23"W x 23"D	Chrome Black	195
	Glass Coffee Table	15.8"H x 39.4"W x 19.7"D	Chrome Black	227
	Rectangular Conference Table	30"H x 36"W x 60"D		1034
	Triangle Glass Top Table	35"H x 35"W x 35"D		290

UPGRADE SEATING

	Barrel Chair	29"H x 28"W x 29"D	Black Only	355
	Leather Loveseat	34"H x 58"W x 36"D	White Black	387
	Leather Sofa	34"H x 80"W x 36"D	White Black	453
	Executive Side Chair	35.25"H x 26.5"W x 23"D	White Only	306
	Chrome Leather Accent Chairs	30.5"H x 30.5"W x 27.5"D	White Only	453
	Chrome Leather Chair	32"H x 36"W x 33"D	White Only	585
	Chrome Leather Sofa	32"H x 81"W x 33"D	White Only	936
	Futon Lounger	32"H x 71"W x 34"D	Vanilla Only	549

****REFUNDS ON UPGRADE FURNISHINGS ARE NOT AVAILABLE AFTER THE ADVANCE ORDER DEADLINE DATE ABOVE****

Please contact **CSS** for custom/specialty items not listed on this order form.

PLEASE READ PAYMENT POLICY

SUBTOTAL	\$
Tax (8.7%)	\$
TOTAL	\$



1921 Bellamah NW
 Albuquerque, NM 87104
 t. 505.243.9889
 f. 505.243.8197
 www.cssabq.com

email us @
 esr@cssabq.com

UPGRADE FURNISHINGS

CONVENTION SERVICES OF THE SOUTHWEST, INC.



**LEATHER OFFICE CHAIR
 WITH MESH BACK**
 34.75" H x 22.75" W x 24" D



**WHITE
 MODERN CHAIR**
 33.5" H x 18.8" W x 18.8" D



**MESH STENO CHAIR
 w/ WHEELS**
 38.5-42.2" H x 27.1" W x 26.7" D



**SODA FOUNTAIN
 BARSTOOL**
 30" H x 17" W x 17" D
 (Available w/ black
 or red seat)



**SWIVEL BARSTOOLS
 WITH
 CURVED BACK**
 32.5" H x 22.5" W x 18" D
 (Available in
 black and white)



(Available
 in black
 or white)

24" BISTRO TABLE shown with **JETSON CHAIRS 15"x15"** (adjustable seat) – rented separately
 White – 23.75" D x 26.25" – 35.75" H (adjustable) – Black – 24" D x 42" H



1921 Bellamah NW
 Albuquerque, NM 87104
 t. 505.243.9889
 f. 505.243.8197
 www.cssabq.com

email us @
 esr@cssabq.com

UPGRADE FURNISHINGS

CONVENTION SERVICES OF THE SOUTHWEST, INC.



RECTANGULAR CONFERENCE TABLE
 30" H x 36" W x 60" D



TRIANGLE GLASS TOP TABLE
 35" H x 35" W x 35" D



31" ROUND GLASS TOP TABLE
 29" H x 31.5" D



GLASS END TABLE
 (Available in chrome or black)
 15" H x 23" W x 23" D



GLASS COFFEE TABLE (Available in chrome or black)
 15.8" H x 39.4" W x 19.7" D



LEATHER SOFA (Available in Black or White)
 35" H X 70" W X 33" D



LEATHER LOVESEAT (Available in Black or White)
 35" H X 59" W X 33" D



BLACK LEATHER BARREL CHAIR
 29" H X 28" W X 29" D



WHITE EXECUTIVE SIDE CHAIR
 35" H X 26" W X 23" D



CHROME LEATHER ACCENT CHAIR
 30.5" H X 30.5" W 27.5" D



WHITE AND CHROME SOFA
 32" H X 81" W 33" D



WHITE AND CHROME CHAIR
 32" H X 80" W 33" D



VANILLA FUTON LOUNGER
 32" H X 71" W 34" D



1921 Bellamah NW
 Albuquerque, NM 87104
 t. 505.243.9889
 f. 505.243.8197
 www.cssabq.com

email us @
 esr@cssabq.com

CARPET ORDER FORM

CONVENTION SERVICES OF THE SOUTHWEST, INC.

Event Name: SWTA 2025	Advance Payment Deadline: Monday, February 3, 2025	Booth # (s):
Company Name:	Telephone #:	
Billing Address:	Fax #:	
City/State/Zip:	Email Address:	
Authorized by:		

STANDARD CARPET

Quantity	Description	Advance Price	Standard Price
	10' x 10' carpet	211	254
	10' x 20' carpet	368	446
	10' x 30' carpet	553	665
	10' x 40' carpet	739	887
	SPECIAL CUT STANDARD CARPET (Carpet rolls are 10' wide, so special cut would be required for sizes smaller than 10' wide or a length other than in a 10' increment.)	\$4.07 per sq. ft.	\$4.88 per sq. ft.
	Visqueen	\$1.36 per sq. ft.	\$1.64 per sq. ft.
	Carpet Padding (100 sq. ft. min)	\$2.01 per sq. ft.	\$2.42 per sq. ft.

STANDARD CARPET COLOR *(please circle color choice)*

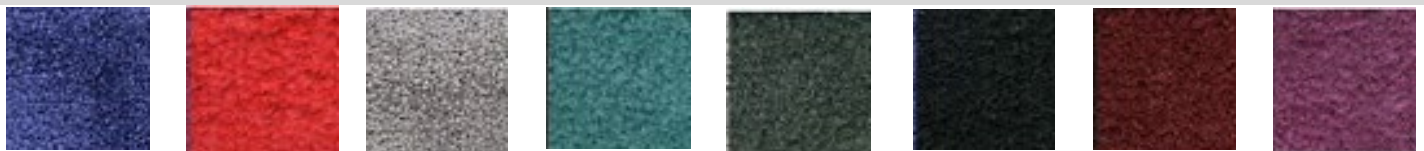

Blue Red Grey Teal Hunter Green Black Burgundy Plum

PAYMENT IN FULL MUST ACCOMPANY YOUR ORDER.

For your convenience, MasterCard, American Express, and Visa credit cards will be accepted.

NO TELEPHONE ORDERS WILL BE ACCEPTED.

****All utility lines must be installed before carpet installation. Utilities should be ordered in advance. ****

PLEASE READ PAYMENT POLICY

SUBTOTAL	\$
Tax (8.7%)	\$
TOTAL	\$



1921 Bellamah NW
 Albuquerque, NM 87104
 t. 505.243.9889
 f. 505.243.8197
 www.cssabq.com

email us @
 esr@cssabq.com

PRESTIGE CARPET ORDER FORM

CONVENTION SERVICES OF THE SOUTHWEST, INC.

Event Name: SWTA 2025	Advance Payment Deadline: Monday, February 3, 2025	Booth # (s):
Company Name:	Telephone #:	
Billing Address:	Fax #:	
City/State/Zip:	Email Address:	
Authorized by:		

****** ORDERS PLACED AFTER THE ABOVE DEADLINE DATE, PLEASE CALL FOR AVAILABILITY AND LATE FEES ******

SPECIAL CUT PRESTIGE CARPET

Enhance your exhibit with 30 oz. plush, heavy-cut polyester pile carpet

Carpet Size _____ x _____ = _____ square feet x \$5.35 = \$ _____ TOTAL

PRESTIGE CARPET COLOR (please circle color choice)

Pink	Magenta	Cherry Red	Red Fire	Cherry Blossom	Hay Loft	Navel
Orange	Butter Cream	Sunshine	Lime Green	Wintergreen	Pine	Forest
Pacific	Orion Blue	Lite Blue	Nautical	Caribbean	Process Blue	Bright Blue
Atlantic	Reflex Blue	Blueberry	Intense Blue	Deep Blue	Navy	Purple
Cream	Vanilla	Snowflake	White	Aluminum	Flannel	Fog
Tanium	Silver Mist	Grey Blue	Medium Grey	Cool Grey	Steel	Charcoal
Grey	English Grey	Smokey	Smoke	Black		

Visqueen is available at **\$1.36** (advanced price) or **\$1.64** (standard price) per square foot installed

_____ x _____ = _____ square feet x \$1.36 or \$1.64 = \$ _____ TOTAL

Carpet Padding is available at **\$2.01** (advanced) or **\$2.42** (standard) per square foot installed (100 sq. ft. min charge)

_____ x _____ = _____ square feet x \$2.01 or \$2.42 = \$ _____ TOTAL

****NO REFUNDS ON SPECIAL ORDER CARPET – ALL SALES ARE FINAL****

Carpet Samples are available upon request – please fill out the mailing information below.

Mail Photo to:	_____
Attention:	_____
Company:	_____
Address:	_____
City:	_____ State: _____ Zip Code: _____
Phone Number:	_____

PAYMENT IN FULL MUST ACCOMPANY YOUR ORDER.

For your convenience, MasterCard, American Express, and Visa credit cards will be accepted.

NO TELEPHONE ORDERS WILL BE ACCEPTED.

****All utility lines must be installed before carpet installation. Utilities should be ordered in advance. ****

PLEASE READ PAYMENT POLICY

SUBTOTAL	\$
Tax (8.7%)	\$
TOTAL	\$



1921 Bellamah NW
 Albuquerque, NM 87104
 t. 505.243.9889
 f. 505.243.8197
 www.cssabq.com

email us @
 esr@cssabq.com

PRESTIGE CARPET COLORS

CONVENTION SERVICES OF THE SOUTHWEST, INC.

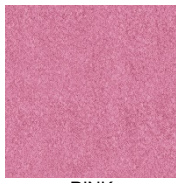

PINK

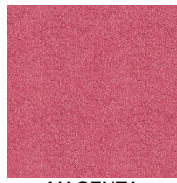

MAGENTA

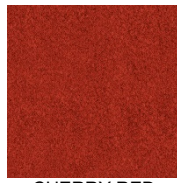

CHERRY RED

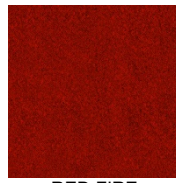

RED FIRE



CHERRY BLOSSOM



HAY LOFT



NAVEL



ORANGE



BUTTER CREAM



SUNSHINE



LIME GREEN

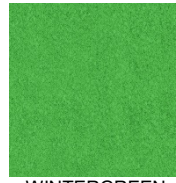

WINTERGREEN

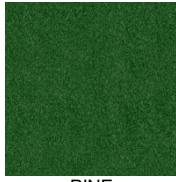

PINE



FOREST



PACIFIC

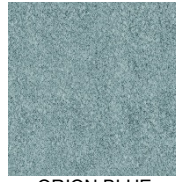

ORION BLUE

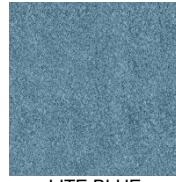

LITE BLUE

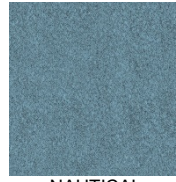

NAUTICAL

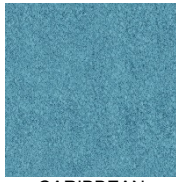

CARIBBEAN

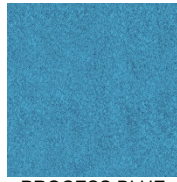

PROCESS BLUE

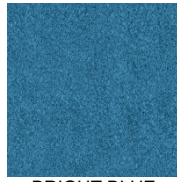

BRIGHT BLUE

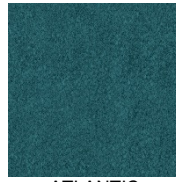

ATLANTIC



REFLEX BLUE



BLUEBERRY

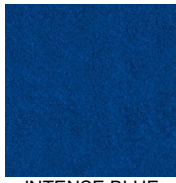

INTENSE BLUE



DEEP BLUE

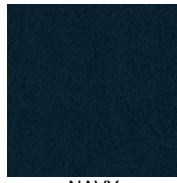

NAVY



PURPLE



CREAM



VANILLA

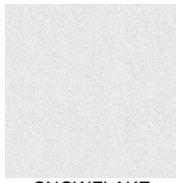

SNOWFLAKE

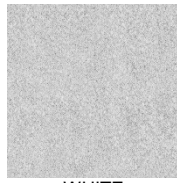

WHITE

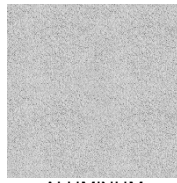

ALUMINUM



FLANNEL



FOG

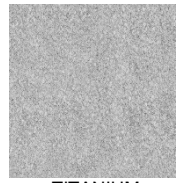

TITANIUM

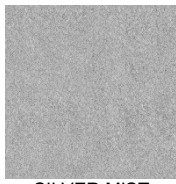

SILVER MIST

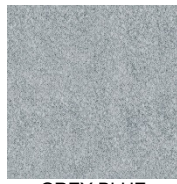

GREY BLUE

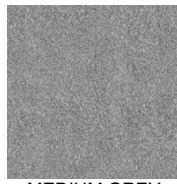

MEDIUM GREY

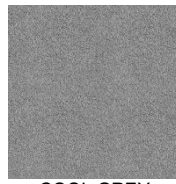

COOL GREY

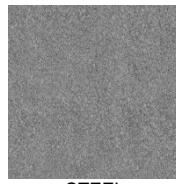

STEEL

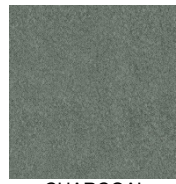

CHARCOAL



GREY

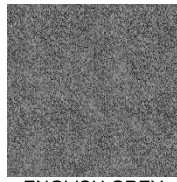

ENGLISH GREY

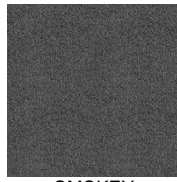

SMOKEY



SMOKE



BLACK



1921 Bellamah NW
 Albuquerque, NM 87104
 t. 505.243.9889
 f. 505.243.8197
 www.cssabq.com

email us @
 esr@cssabq.com

RENTAL DISPLAY

CONVENTION SERVICES OF THE SOUTHWEST, INC.

Event Name: SWTA 2025	Advance Payment Deadline: Monday, February 3, 2025	Booth # (s):
Company Name:	Telephone #:	
Billing Address:	Fax #:	
City/State/Zip:	Email Address:	
Authorized by:		

Rental Display Units

Please contact CSS Exhibitor Services Department to order Rental Display Units at

Email: esr@cssabq.com

Or

Phone: (505) 243-9889

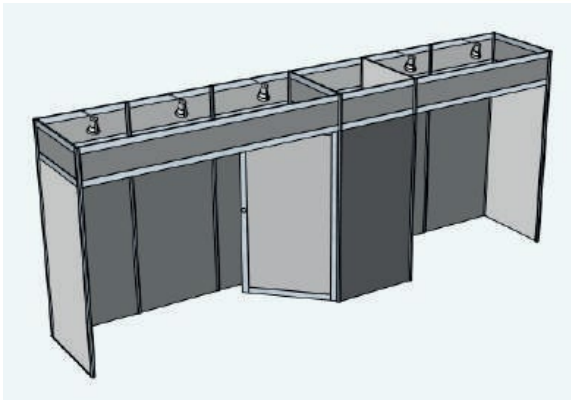
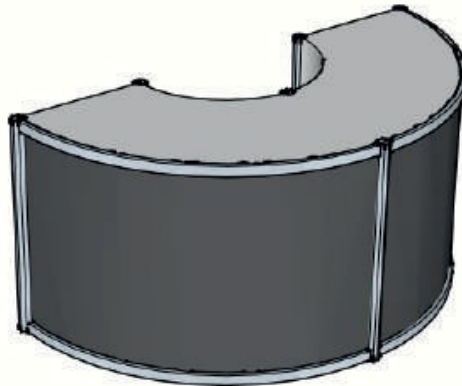
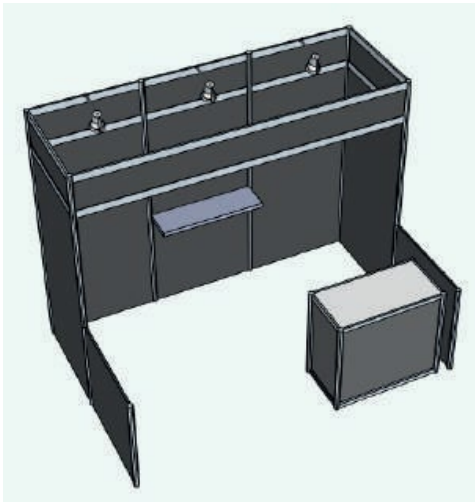



1921 Bellamah NW
 Albuquerque, NM 87104
 t. 505.243.9889
 f. 505.243.8197
 www.cssabq.com

email us @
 esr@cssabq.com

LABOR ORDER FORM

CONVENTION SERVICES OF THE SOUTHWEST, INC.

Event Name: SWTA 2025	Advance Payment Deadline: Monday, February 3, 2025	Booth # (s):
Company Name:	Telephone #:	
Billing Address:	Fax #:	
City/State/Zip:	Email Address:	
Authorized by:		

Display labor & Forklift will be billed in 1/2 hour increments with a **one-hour minimum**.

DISPLAY LABOR RATES	Advance Price Per Person / Per Hour	Standard Price Per Person / Per Hour
Straight time – 8:00AM – 4:30PM (Weekdays)	\$121.00	\$145.00
Overtime – Before 8:00AM and after 4:30PM (Weekdays & Saturdays)	\$171.00	\$195.00
Sundays and Holidays	\$221.00	\$245.00

FORKLIFT RATES WITH OPERATOR	Advance Price Per Person / Per Hour	Standard Price Per Person / Per Hour
Straight time – 8:00AM – 4:30PM (Weekdays)	\$216.00	\$259.00
Overtime – Before 8:00AM and after 4:30PM (Weekdays & Saturdays)	\$266.00	\$309.00
Sundays and Holidays	\$316.00	\$359.00

****Exhibitor must contract all forklift operation with the official service contractor.****

SUPERVISION OF ALL LABOR IS REQUIRED. PLEASE INDICATE SUPERVISION PLAN:

PLAN A - EXHIBITOR SUPERVISION

All work is performed under the supervision of the Exhibitor. Starting time can be guaranteed only in those instances where persons are requested for the start of the working day, 8:00AM. If labor is not picked up or canceled without 24-hour's notice, your estimated labor hours will be charged. **The exhibitor must check in at the service desk to pick up labor ordered and check labor out at the service desk, upon completion of the work. If display materials have not arrived by scheduled labor install times, your estimated labor hours will be charged.**

Representative Name/Company

PLAN B – CSS SUPERVISION

***Please fill out all outbound shipping information.

All work is performed under the direction of **CSS** personnel. Our charge for this service is 30% of your total labor bill (**\$50 minimum**). In order to complete the work without your representative present, we must have set-up instructions (blueprints/floor plans, etc.). **If display materials have not arrived by scheduled labor install times, your estimated labor hours will be charged. You must also include outbound shipping labels and shipping instructions with your labor order.**

Please complete this section:

	Labor Type	No. of People	Date	Time	Approximate Hours	Estimated Cost
INSTALLATION						
DISMANTLE						

PLEASE READ PAYMENT POLICY

SUBTOTAL	\$
Tax Exempt	\$ -----
TOTAL	\$



1921 Bellamah NW
 Albuquerque, NM 87104
 t. 505.243.9889
 f. 505.243.8197
 www.cssabq.com

email us @
 esr@cssabq.com

VEHICLE SPOTTING ORDER FORM

Mobile Units / Motorized Vehicles

CONVENTION SERVICES OF THE SOUTHWEST, INC.

Event Name: SWTA 2025	Advance Payment Deadline: Monday, February 3, 2025	Booth # (s):
Company Name:	Telephone #:	
Billing Address:	Fax #:	
City/State/Zip:	Email Address:	
Authorized by:		

DIRECT MOBILE UNITS / MOTORIZED VEHICLES / EXHIBIT AREA

Exhibitors or agents with mobile or motorized equipment will require guidance to their respective booths. This guidance is required and provided by **CSS** to prevent damage that may occur to exhibits, or property of others, or when necessary to move crates that may be in aisles.

Exhibitors may drive their motorized equipment in and out of the exhibit areas with **CSS** spotters, or have **CSS** supply an operator when available.

Mobile units are to have 1/4 tank of gas or less and once vehicle is in place, battery is to be disconnected, gas cap locked or taped.

EXHIBIT AREA:

MOBILE UNITS

\$ 250 PER UNIT (Round Trip)

Number of Units: _____ Type: _____

Dimensions of Largest Unit:

Height: _____ Width: _____ Length: _____ Weight: _____

Comments/Special Handling Requirements: _____

PLEASE READ PAYMENT POLICY

SUBTOTAL	\$
Tax Exempt	\$ _____
TOTAL	\$



1921 Bellamah NW
Albuquerque, NM 87104
t. 505.243.9889
f. 505.243.8197
www.cssabq.com

email us @
esr@cssabq.com

MATERIAL HANDLING INFORMATION & LIMITS OF LIABILITY

CONVENTION SERVICES OF THE SOUTHWEST, INC.

MATERIAL HANDLING (DRAYAGE) INFORMATION

- ❖ As an exhibitor, you are responsible for providing your carrier with proper delivery and pickup information for your materials, both in advance and at show site.
- ❖ Please prepay all shipping charges. **CSS** cannot accept or be responsible for collect shipments. Keep in mind, **material handling** (drayage) charges and shipping charges are not the same thing.
 - “Drayage” is the movement of freight from decorator warehouse or show-site dock to exhibit booth and back out to the “freight carrier” at the show-site dock.
 - “Shipping” is movement of freight from city to city on a designated carrier.
- ❖ All shipments must be accompanied by a bill of lading. Shipments received without receipts, freight bills, or specified unit counts (UPS, Federal Express, personal vehicles, etc.) will be delivered to the exhibitor’s booth without guarantee of piece count or condition. No liability will be assumed by **CSS** for such shipments. Shipments without certified weight documents will be estimated by **CSS**. (**This estimate will be binding on both parties and no adjustments will be made after the show closes.*)
- ❖ **We will accept all cartons, crates, and skidded materials at the warehouse. Do not ship uncrated materials to the warehouse. Loose materials, uncrated materials, or machinery not banded to skids will be accepted at show site only.**
- ❖ **All van line shipments must be accompanied by a “certified weight ticket”, with heavy & light weights otherwise CSS will estimate freight weight, which will be binding on both parties and no adjustments will be made after the show closes.**
- ❖ All shipments for the show received either in advance or at show site will be assessed material handling charges by **CSS**. (*Please refer to the **Material Handling Rate Sheet**.*) All material handling rates are roundtrip and are based on incoming weights only. Overtime charges may apply under some circumstances, such as carrier-delayed freight delivered after designated move-in times.
- ❖ “Off-Target” freight is when freight arrives at the advance warehouse prior to the first scheduled day or after the last scheduled day indicated on both the show information sheet and the Material Handling Rate Sheet. If freight is delivered prior to the first scheduled day of advance freight receipt, storage charges may apply. If freight is delivered after the last scheduled day of advance freight receipt, additional delivery charges may apply.

MATERIAL HANDLING INCLUDES:

- Storing your booth, equipment, and materials in our warehouse for up to 30 days in advance of the show. (*Advance shipments only*)
- Delivering materials to your booth at show site.
- Removing empty containers from your booth, storing them for the duration of the show, then returning them to your booth at close of show.
- Moving packed and labeled materials from your booth to the dock area at close of show and reloading them on designated carriers based on information provided on your show site bill of lading (obtained from **CSS** Service Center).

MATERIAL HANDLING DOES NOT INCLUDE:

- Labor and/or equipment for uncrating, unskidding, assembling, positioning, leveling, dismantling, re-crating, and reskidding machinery and/or equipment for exhibitors. Additional labor to accomplish these tasks may be ordered from the **Labor Order Form** enclosed in the Exhibitor Service Kit.
- Scheduling any carrier for pick-up or delivery of your materials, if other than the official show carrier(s). All carriers must be checked in by the designated re-routing time or exhibitor freight will be either re-routed with show carrier or returned to **CSS** warehouse at exhibitor expense. Please refer to **Material Handling Rate Sheet** for re-route times.



1921 Bellamah NW
Albuquerque, NM 87104
t. 505.243.9889
f. 505.243.8197
www.cssabq.com

email us @
esr@cssabq.com

MATERIAL HANDLING INFORMATION & LIMITS OF LIABILITY

CONVENTION SERVICES OF THE SOUTHWEST. INC.

LIMITS OF LIABILITY

PLEASE READ:

CSS' liability is limited to physical loss or damage to a specific article which is lost or damaged, and in any event **CSS'** maximum liability will be limited to \$.30 per pound, per article with a maximum liability of \$50.00 per item or \$1,000.00 per shipment, whichever is less.

CSS will not be liable to any extent whatsoever for any actual, potential, or assumed loss of profits or revenues, or for any collateral costs, which may result from any loss or damage to an exhibitor's materials which may make it impossible or impractical to exhibit said materials.

Claims for loss or damage that are not submitted to **CSS** within 30 days of the close of the show shall be considered waived.

The consignment or delivery of a shipment to **CSS** by an exhibitor, or by any shipper on behalf of the exhibitor, will be construed as an acceptance by such exhibitors (and/or shippers) of the terms and conditions set forth in this document.

To expedite removal of materials from the show site, **CSS** shall have the authority to change designated carriers, if such carriers do not pick-up on time. Where the exhibitor makes no disposition, materials will be either taken to a warehouse to await exhibitor's shipping instructions (in which case "return to the warehouse" charges will be incurred by exhibitor) or shipped to the exhibitor's address. Labeled shipments left in the facility at the close of the show without a bill of lading will be re-routed with the preferred carrier. No liability will be assumed as a result of such re-routing or handling.

INSURE ALL SHIPMENTS FROM THE TIME THEY LEAVE YOUR COMPANY UNTIL THEY ARE RETURNED FROM THE SHOW. Your present insurance carrier can add a rider to your current policy.

IT IS THE RESPONSIBILITY OF THE EXHIBITOR TO MAKE ALL ARRANGEMENTS FOR PICK-UP AND DELIVERY OF FREIGHT. IF YOU CHOOSE TO USE OUR PREFERRED CARRIER, WE WILL MAKE ALL OUTBOUND ARRANGEMENTS FOR YOU. A COMPLETED BILL OF LADING WILL STILL BE REQUIRED.

CSS will not be responsible for:

- Shipments delivered to the wrong booth due to improper labeling by the exhibitor.
- Misdirected shipments or removal of crates to storage due to old labels appearing on crates.
- Damage to uncrated or improperly packed materials, or concealed damage.
- Loss, theft, or disappearance of Exhibitor's material after it has been delivered to the exhibit booth.
- Loss, theft, or disappearance of Exhibitor's material prior to materials being picked up from exhibit booths for reloading after close of the show. **CSS** will check all bills of lading covering outgoing shipments at time of actual pick up from the exhibit booth. Corrections will be made to the bill of lading where discrepancies occur.
- Loss, damage, or delay due to fire, acts of God, strikes, lockouts, work stoppages of any kind, or any causes beyond **CSS** control.

The exhibitor accepts the responsibility for the payment of charges in connection with the handling of the shipment and guarantees payment to CSS for the incurred services described herewith. SEE PAYMENT POLICY.



1921 Bellamah NW
Albuquerque, NM 87104
t. 505.243.9889
f. 505.243.8197
www.cssabq.com

email us @
esr@cssabq.com

MATERIAL HANDLING AGREEMENT RATE SHEET AND ORDER FORM

CONVENTION SERVICES OF THE SOUTHWEST, INC.

Event Name: SWTA 2025	Advance Payment Deadline: Monday, February 3, 2025	Booth # (s):
Company Name:	Telephone #:	
Billing Address:	Fax #:	
City/State/Zip:	Email Address:	
Authorized by:		

YOU ARE ENTERING A CONTRACT WHICH LIMITS YOUR POSSIBLE RECOVERY IN CASE OF LOSS OR DAMAGE. Acceptance of CSS' payment policy, material handling terms and conditions, and limits of liability will be construed when any of the following conditions are met: This Material Handling Agreement (MHA) is signed; Exhibitor's materials are delivered to CSS's warehouse or to an event site for which CSS is the Official Show Contractor; or an order for labor and/or rental equipment is placed by Exhibitor with CSS.

ADVANCE FREIGHT RECEIVING Monday – Friday 8:00AM – 5:00PM Tuesday, January 21 – Friday, February 14, 2025 ADVANCE SHIPPING ADDRESS	
Ship To:	Exhibitor Name and Booth # SWTA 2025 c/o CSS ABF Freight 2943 E Wieding Road Tucson, AZ 85706
Number of Pieces:	Estimated Weight:
Inbound Freight Carrier:	

FIRST DAY FOR DIRECT FREIGHT Tuesday, February 18, 2025 --- 8:00AM – 5:00PM Wednesday, Feb. 19, 2025 --- 8:00AM – 12:00PM DIRECT SHIPPING ADDRESS	
Ship To:	Exhibitor Name and Booth # c/o CSS SWTA 2025 Tucson Convention Center – Exhibit Halls B&C 260 S Church Ave. Tucson, AZ 85701
Number of Pieces:	Estimated Weight:
Inbound Freight Carrier:	

Our preferred freight carrier is: ArcBest (ABF Freight) 1-800-654-7019

****Freight will be re-routed from show floor on Thursday, February 20, 2025 @ 5:00PM****

SAMPLE: Weight <u>500</u> ÷ 100 = Total CWT <u>5</u> @ <u>\$ 120</u> per cwt = <u>\$ 600</u>

ADVANCE FREIGHT RATES: (includes crates, skidded, and carton materials)

\$ 120 per cwt. **\$ 240** minimum charge
Weight _____ ÷ 100 = Total CWT _____ @ **\$ 120** per cwt = \$ _____

DIRECT FREIGHT RATES: (includes crates, skidded, and carton materials)

\$ 109 per cwt. **\$ 218** minimum charge
Weight _____ ÷ 100 = Total CWT _____ @ **\$ 109** per cwt = \$ _____

All charges are per hundred pounds (cwt) with a 200 lb. minimum per shipment. All shipments are rounded to the next hundred pounds.

ADDITIONAL RATES:

“Late Shipments” and “Off Target” freight will be charged an **additional \$24 per cwt.** (200 lb. minimum applies)
“Small Package” or shipments weighing 30 lbs. or less will be charged a **\$67 material handling fee.**
Banding and Shrink Wrap will be charged at **\$78** per skid or crate.
Outbound Material Handling Only (freight handled at close of show only) will be charged **\$65 per cwt.** (200 lb. minimum applies)

PLEASE READ PAYMENT POLICY

SUBTOTAL	\$ _____
Tax Exempt	\$ -----
TOTAL	\$ _____

ADVANCE WAREHOUSE SHIPPING LABELS



ADVANCE WAREHOUSE

CONVENTION SERVICES OF THE SOUTHWEST, INC.

TO: _____

(Exhibiting Company Name)

BOOTH #: ____ NO. ____ of ____ PCS

SWTA 2025

c/o CSS

ABF Freight

2943 E Wieding Road

Tucson, AZ 85706

Warehouse Hours: M-F - 8:00AM-5:00PM

MUST ARRIVE BY: Fri., February 14, 2025

RUSH



ADVANCE WAREHOUSE

CONVENTION SERVICES OF THE SOUTHWEST, INC.

TO: _____

(Exhibiting Company Name)

BOOTH #: ____ NO. ____ of ____ PCS

SWTA 2025

c/o CSS

ABF Freight

2943 E Wieding Road

Tucson, AZ 85706

Warehouse Hours: M-F - 8:00AM-5:00PM

MUST ARRIVE BY: Fri., February 14, 2025

RUSH

DIRECT SHIPPING LABELS



DIRECT TO SHOW

CONVENTION SERVICES OF THE SOUTHWEST, INC.

TO: _____

(Exhibiting Company Name)

BOOTH #: ____ NO. ____ of ____ PCS

SWTA 2025

c/o CSS

Tucson CC – Exhibit Halls B&C

260 S Church Ave.

Tucson, AZ 85701

Must NOT arrive before 2/18/25

DIRECT Shipments Received:

Tue., Feb. 18, 2025 – 8:00AM – 5:00PM

Wed, Feb. 18, 2025 – 8:00AM – 10:00AM

RUSH



DIRECT TO SHOW

CONVENTION SERVICES OF THE SOUTHWEST, INC.

TO: _____

(Exhibiting Company Name)

BOOTH #: ____ NO. ____ of ____ PCS

SWTA 2025

c/o CSS

Tucson CC – Exhibit Halls B&C

260 S Church Ave.

Tucson, AZ 85701

Must NOT arrive before 2/18/25

DIRECT Shipments Received:

Tue., Feb. 18, 2025 – 8:00AM – 5:00PM

Wed, Feb. 18, 2025 – 8:00AM – 10:00AM

RUSH



1921 Bellamah NW
 Albuquerque, NM 87104
 t. 505.243.9889
 f. 505.243.8197
 www.cssabq.com

email us @
 esr@cssabq.com

OUTBOUND SHIPPING INFORMATION

CONVENTION SERVICES OF THE SOUTHWEST, INC.

Event Name: SWTA 2025	Advance Payment Deadline: Monday, February 3, 2025	Booth # (s):
Company Name:	Telephone #:	
Billing Address:	Fax #:	
City/State/Zip:	Email Address:	
Authorized by:		

EVERY OUTBOUND SHIPMENT WILL REQUIRE A **CSS** BILL OF LADING AND LABELS. WE WOULD BE HAPPY TO PREPARE THESE FOR YOU IN ADVANCE AND WILL HAVE THEM AVAILABLE AT THE **CSS** SERVICE DESK FOR YOU TO REVIEW AND SIGN. TO TAKE ADVANTAGE OF THIS SERVICE, PLEASE COMPLETE AND RETURN THIS FORM.

*This form is required when labor is **CSS** supervised.*

SHIPPING INFORMATION (IMPORTANT: If your freight is forwarding to another show, be sure to include the show name and your booth number):

FROM: SHIPPER/EXHIBITOR NAME: _____
 BILLING ADDRESS: _____

 CITY: _____ STATE: _____ ZIP: _____

TO: COMPANY NAME: _____
 DELIVERY ADDRESS: _____

 CITY: _____ STATE: _____ ZIP: _____
 PHONE#: _____ ATTN: _____
 SPECIAL INSTRUCTIONS: _____

METHOD OF SHIPMENT Please specify your choice by checking the following:

- The preferred carrier, **ArcBest (ABF Freight)**, is authorized to ship show materials to the above address. *(Exhibitor must contact ABF directly for quotes if needed at 800-654-7019 or tradeshowsupport@arcb.com.)*
- The assigned carrier **PRE-SCHEDULED (by exhibitor)** to pick-up during show move-out is:
(Please note the Exhibitor is responsible for scheduling carriers other than the preferred Show Carrier.)
 - Common Carrier _____
 - Van Line _____
 - Air Freight _____

NUMBER OF DESIRED SHIPPING LABELS: _____ *(Fed Ex and UPS shipping labels are not available)*

- Once your shipment is packed and ready to be picked up, please return the BOL to the Exhibitor Services Center.
- Verify the piece count, weight, and that a signature is on the BOL prior to shipping out.
- Shipments without paperwork turned in will be shipped through Preferred Show Carrier at Exhibitor's expense.

Official Transportation Provider *via the ABF Freight® Network*

Let ArcBest® make your next trade show the easiest you have ever attended!

We have over **100** years of experience in the freight industry and a dedicated Trade Show division with service through North America through the ABF Freight® network.

Choose guaranteed, expedited shipping solutions – air or ground – with special discounted rates for your inbound and outbound shipments.

For personalized quotes, please call

800-654-7019

Our Services Include:

Priority handling of your inbound and outbound shipments

Guaranteed expedited air and ground services

LTL Ground Transportation

International Transportation

Trust your important trade show shipment to the leader in exhibition transportation services.

ArcBest®
More Than Logistics™

REQUEST FOR INFORMATION

ArcBest® Trade Show Services

Exhibiting Company _____ Contact Name _____

Title _____ Email _____ Phone _____

SHIPPER INFORMATION

Company _____

Address _____

City _____ State _____ Zip _____

Pickup Date/Time _____

FREIGHT INFORMATION

Piece Count and Type _____

Total Weight _____

Dimensions (L) _____ (W) _____ (H) _____

SHIP TO: Warehouse Show Site

Show Name _____

Booth No. _____

Contractor _____

Show Dates _____

Address _____

City _____ State _____ Zip _____

Delivery Date _____

ADDITIONAL INFORMATION

Residential Pickup Inside Pickup

Liftgate Dock

Would you like an ArcBest Trade Show Coordinator to contact you with a quote or information? YES NO

If you are faxing this form, please print a copy, complete the requested information, and then fax to (844) 718-7620.

If you are completing electronically, you can either print and fax your request or click on the submit button to send your request to one of our Trade Show specialists.

800-654-7019

tradeshow@arcb.com | arcb.com



8401 McClure Drive • Fort Smith, AR • 72916



1921 Bellamah NW
 Albuquerque, NM 87104
 t. 505.243.9889
 f. 505.243.8197
 www.cssabq.com

email us @
 esr@cssabq.com

CLEANING ORDER FORM

CONVENTION SERVICES OF THE SOUTHWEST, INC.

Event Name: SWTA 2025	Advance Payment Deadline: Monday, February 3, 2025	Booth # (s):
Company Name:	Telephone #:	
Billing Address:	Fax #:	
City/State/Zip:	Email Address:	
Authorized by:		

CLEANING SERVICES (select only one of the services below)

SERVICES AVAILABLE		
Quantity (# of booths)	Description	Price
	Initial Cleaning (Vacuum & empty wastebasket(s) before first show day only)	\$.54 per sq. ft. (One Day)
	Daily Cleaning (Vacuum & empty wastebasket(s) for all show days)	\$.48 per sq. ft. (Daily)
	Daily Porter Service (Empty wastebasket(s) and periodic trash pick-up during show hours)	\$2.14 per sq. ft. (Daily)

PLEASE COMPUTE COST BELOW.

(To compute booth size: Length x Width)

NOTE: A MINIMUM OF 100 SQ. FT. WILL BE ASSESSED FOR TOTAL SQ. FT. AMOUNT.

# of Booths	X	Booth Size	=	Total sq. ft.	X	Rate per sq. ft.	X	# of Days	=	Subtotal
_____	X	_____	=	_____	X	_____	X	_____	=	_____

Companies who leave garbage in aisles or have excessive giveaway boxes will be mandated daily cleaning.

Please bring any discrepancies regarding these services to our attention prior to show close.
 CSS is unable to adjust invoices after the close of the show.

PLEASE READ PAYMENT POLICY

SUBTOTAL	\$
Tax (8.7%)	\$
TOTAL	\$



1921 Bellamah NW
 Albuquerque, NM 87104
 t. 505.243.9889
 f. 505.243.8197
 www.cssabq.com

email us @
 esr@cssabq.com

SIGN/GRAPHICS ORDER FORM

CONVENTION SERVICES OF THE SOUTHWEST, INC.

Event Name: SWTA 2025	Advance Payment Deadline: Monday, February 3, 2025	Booth # (s):
Company Name:	Telephone #:	
Billing Address:	Fax #:	
City/State/Zip:	Email Address:	
Authorized by:		

Fill out section below. Include copy & rough layouts on a separate piece of paper and mail or fax to us. Please circle orientation of signage.

Quantity	Size	Orientation	Letter Color	Advance Price	Standard Price	Total
	7" x 11"	Vertical Horizontal		21	26	
	7" x 44"	Vertical Horizontal		48	58	
	11" x 14"	Vertical Horizontal		60	68	
	14" x 22"	Vertical Horizontal		74	89	
	22" x 28"	Vertical Horizontal		100	120	
	24" x 36"	Vertical Horizontal		135	162	
	28" x 44"	Vertical Horizontal		188	227	
	Meter Board (1 meter x 8')	Vertical (unframed)		425	509	
	Custom Signs	Vertical Horizontal		Contact for Quote		
	Banners			Contact for Quote		

PLEASE READ PAYMENT POLICY.

SUBTOTAL	\$
Tax (8.7%)	\$
TOTAL	\$

Orders placed within 48 hours of show start date will be charged at 150% of the standard price and may be subject to additional delivery or handling charges.

Note: Prices are based on DIGITAL OUTPUT mounted on Foam Core.
 If you prefer other materials such as Fabric, Komatex, Plexi Glass, Koraplast, and/or Gator Foam, they will be quoted upon request.

Guidelines for Submitting Artwork:

Artwork should be submitted through the FTP website (please contact us for detailed instructions) or via e-mail in a zip folder (limited to 10 MB per email). In order for us to use a graphic file it must be saved in one of the following file formats:

VECTOR FILES: .AI, .EPS (Please change fonts to outline or include font types.)
RASTER FILES: .PSD, .TIF, .EPS, .JPG

When submitting a raster file, the **optimal resolution is 100 PPI** at 100% or **200 PPI** if file is built at 1/2 size. Lower resolution files will have a negative result on the image quality.

When submitting files, please include the following: Sign/Graphics Order Form, email address/originator of the artwork, printed color copy of the artwork, separations, and CMYK values.

PLEASE ATTACH SIGN COPY AND ANY SPECIAL INSTRUCTIONS:



1921 Bellamah NW
Albuquerque, NM 87104
t. 505.243.9889
f. 505.243.8197
www.cssabq.com

email us @
esr@cssabq.com

FIRE REGULATIONS

CONVENTION SERVICES OF THE SOUTHWEST, INC.

FIRE PREVENTION REGULATIONS

PLEASE READ CAREFULLY AND COMPLETELY!

Aisles are not to be blocked unless it is clearly indicated on the Fire Marshal approved floor plan. Exits, exit signs, and firefighting equipment are not to be blocked or concealed from view in any manner.

Fire inspections may be conducted during the course of move-in and move-out. A pre-opening inspection shall be conducted. Spot inspections may be conducted during the course of the show. The show will not be permitted to open without the approval of the Fire Marshal or his/her authorized representative.

If violations are found during the exhibit, booth(s) shall be subject to closure. Booth operators or employees may also be subject to a citation, which may result in up to a \$500.00 fine, 90 days in jail, or both.

Exhibit booths shall be constructed of non-combustible or limited-combustible materials.

Acoustical and decorative material including, but not limited to cotton, hay, paper, straw, moss, split bamboo, and wood chips shall be flame retardant treated to the satisfaction of the authority having jurisdiction. **Materials that cannot be treated for flame retardancy shall not be used.** Foamed plastics and materials containing foamed plastics used and decorative objects such as, but not limited to mannequins, murals, and signs shall have a maximum heat release rate for any single fuel package of 150 kW when tested in accordance with UL 1975, Standard for Fire Tests for Foamed Plastic used for Decorative Purposes.

FIELD FLAME TEST: Flame retardant materials shall not ignite and spread over the surface when exposed to open flame.

1. Oilcloth, tarpaper, nylon, plastic cloths, and certain other plastic materials cannot be made flame retardant and their use is prohibited.
2. Compressed flammable gases flammable/combustible liquids and hazardous chemicals are prohibited inside the building.
3. The use of LP-Gas cylinders is prohibited. **Exception:** Non-refillable cylinder may be used where permitted by the authority having jurisdiction. Compressed Gas **only** 12-16oz.
4. Hazardous chemicals and materials including pesticides, fungicides, insecticides, caustics, corrosives, oxidizers, flammable, poisons, and toxins are prohibited inside the building.
5. Combustible materials (i.e. crates and boxes) shall be limited to a one (1)-day supply and shall be maintained in an orderly fashion. **Storage of any combustible materials behind booths is prohibited.**

SPECIAL REQUIREMENTS: Vehicles on display within an exposition facility shall comply with the following:

1. All fuel tank openings shall be locked and sealed in an approved manner to prevent the escape of vapors.
2. Battery terminals shall be disconnected and taped off, using a non-metallic tape.
3. Fueling and defueling within the facility is prohibited.
4. Vehicles shall not be moved at any time during show hours.
5. Fuel Limit: Fuel tank shall not exceed one quarter of the tank's capacity or 5 gallons, whichever is less.
6. Vehicles, boats, and similar exhibited products having over 100 sq. ft. (9.3 sq. m.) of roofed area shall be provided with smoke detectors acceptable to the authority having jurisdiction.

OPEN FLAME DEVICES: Neither open flame devices nor pyrotechnic devices shall be used in any assembly occupancy. Cooking and/or warming devices that produce gas laden vapors shall be electric. Sterno may be used for warming trays. Cooking devices shall be approved by a recognized testing laboratory (i.e. UL, FMO).

1. Cooking and/or warming devices shall be isolated from the public, either placing the device a minimum of four (4) feet back from the front of the booth, or providing a barrier between the cooking and/or warming device and the public.
2. Individual cooking and/or warming devices shall not exceed 228" surface area.
3. The label surface holding the cooking and/or warming device(s) shall be of a non-combustible material.
4. A minimum of two (2) feet shall be kept between cooking devices.
5. Combustible materials shall be kept three (3) feet away from any cooking and/or warming device.
6. A 40 BC extinguisher and lid or an approved automatic extinguishing system shall be provided with any booth utilizing

cooking and/or warming devices.

7. Type K fire extinguishers shall be utilized with deep fat fryers or appliances emitting grease laden vapors.
8. Lids to one side, to put on cooking/warming devices.

CANDLES AND OTHER OPEN-FLAME DEVICES: The use of candles and other open-flame devices shall be in accordance with the following:

1. Class I and II liquids and liquefied petroleum gasses shall not be used.
2. Liquid or solid-fueled lighting devices containing more than 8 ounces must self-extinguish and not leak fuel at a rate of more than ¼ teaspoon per minute if tipped over.
3. The device or holder shall be constructed to prevent the spilling of liquid fuel or wax at the rate of more than ¼ teaspoon per minute when the device or holder is not in an upright position.
4. The device or holder shall be designed so that it will return to the upright position after being tilted to an angle of 45 degrees from vertical. EXCEPTION: Units that self-extinguish if tipped over and that do not spill fuel or wax at the rate of more than ¼ teaspoon per minute if tipped over.
5. The flame shall be enclosed except as follows: **a)** openings on the sides shall not be more than 3/8 inch in diameter; **b)** openings on the top and the distance to the top shall be such that a single layer of tissue paper placed on the top will not ignite in ten (10) seconds.
6. Chimneys shall be made of noncombustible materials. Such chimneys shall be securely attached to the open-flame device. EXCEPTION: The chimney need not be attached to any open-flame device that will self-extinguish if the device is tipped over.
7. Shades, if used, shall be made of noncombustible materials and securely attached to the open-flame device holder of chimney.
8. Candelabras with flame-lighted candles shall be securely fastened in place to prevent overturning and must be located away from occupants using the area and away from possible contact with drapes, curtains, or other combustibles.
9. When in the opinion of the Fire Marshall, adequate safeguards have been taken, hand-held flame lighted candles can be allowed. Hand-held candles shall not be passed from one person to another while ignited.

FLAMING FOODS AND BEVERAGES: Flaming Foods and Beverages shall be in accordance with the following:

1. Flammable liquids used in the preparation of flaming food and beverage shall be dispensed from a (1) once container or from a container not to exceed a one (1)-quart capacity and having a controlled pouring device that limits the flow to one (1) ounce.
2. Flaming foods or beverages shall be prepared only in the immediate vicinity of the table being served. Flaming food or beverages shall not be transported or carried while burning.
3. The person preparing or serving the flaming foods or beverages shall have a wet cloth towel immediately available for use in smothering the flames in the event of an emergency.
4. The serving of flaming foods or beverages shall be done in a safe manner and shall not create high flames.
5. The pouring, ladling, or spooning of flammable foods or beverages is restricted to a maximum height of eight (8) inches above the receiving receptacle.

IN ALL CASES:

1. All fuel containers shall be secured to prevent spillage when not in use.
2. Fuel canisters shall be safety sealed for storage.
3. Storage or refueling containers are not to exceed a maximum of 16 ounces.
4. The storage of **ANY** combustible behind booths is prohibited.
5. The pouring, ladling, or spooning of flammable liquid is restricted to a maximum height of 8 inches above the receiving receptacle.

No exhibition or show will be permitted to open without the approval of the Fire Marshal or his/her authorized representative. Fire inspections may be conducted during the course of move-in and tear down. A pre-opening inspection shall be conducted. Spot inspections may be conducted during the course of the show. If violations are found during the exhibition or show, violating booth(s) shall be subject to closure.

The Fire Marshal's Office understands that each exhibition, show, or event are different. Depending on the circumstances of the event additional items may need to be addressed. In these instances it will be necessary to follow IFC Section 2416.1 which states in part: When in the opinion of the Fire Marshal, it is essential for public safety in a place of assembly or any other place where people congregate, due to the number of persons, or the nature of the performance, exhibition, display, contest, or activity, the owner, agent, or lessee, shall employ two or more qualified persons from within the fire department. Qualified persons would be as necessary for the greatest life safety, i.e. firefighters, paramedics, full truck crews, etc.



1921 Bellamah NW
Albuquerque, NM 87104
t. 505.243.9889
f. 505.243.8197
www.cssabq.com

email us @
esr@cssabq.com

SAFETY TIPS AND INFORMATION

CONVENTION SERVICES OF THE SOUTHWEST, INC.

Safety is very important for everyone working in the Exhibit Hall.

Convention Services of the Southwest, Inc (**CSS**) values safety throughout our organization and demonstrates it in the work we perform. By following the safety guidelines below, you will be doing your part in creating a safe work environment.

SAFETY GUIDELINES

- Only authorized personnel and employees allowed, all others are prohibited during move-in and move-out.
- Be aware of your surroundings. You are in an active work area with changing conditions. Pay attention.
- All exhibitors and attendees enter at their own risk. Do not enter the dock/yard areas – these areas can be particularly dangerous.
- Stay clear of machinery. Look for obstacles, machinery, and equipment that are in use. Drivers of these vehicles or machines may not be able to see you.
- Never stand on furniture. These objects are not designed to support your standing weight.
- Prevent electrical shocks, falling items, and damage to materials. Do not attach items or equipment to the drapes or metal framework provided for your booth. This can cause serious injury or damage to materials.
- Wear closed toe shoes.
- Clean up or report spills.
- Practice good housekeeping. Keep aisles free and clear of any and all debris.
- Be aware of your surrounding areas for electrical cords or other trip hazards. Sometimes the view of equipment or items may be obstructed.
- Protect valuables at show site.
- Report any fires immediately.

If you notice anything unsafe, please contact a **CSS** employee immediately.

During move-in and move-out unsupervised individuals under the age of 18 are prohibited from being on or around the show floor. Show sites during these times are similar to a construction zone and considered to be hazardous. OSHA regulations prohibit minors from being present in a hazardous work environment.

WORK ZONE

Customer acknowledges that the show site and surrounding areas are active work zones. Customer, its agents, employees and representative are present at their own risk.





Display of Motorized Vehicles

Your Event Coordinator must be notified in advance if motorized vehicles are to be displayed during an event. Displayed motorized vehicles shall comply with the following and may also have to comply with additional rules and regulations required by the Fire Inspector.

Any use or storage of LPG/CNG is forbidden within the building unless approved by TFD.

Any vehicle within the buildings or within 20' of any building opening shall comply with the following regulations:

All vehicles must have a notice posted (form attached below) on the dashboard declaring that the battery supply has been disconnected and that the fuel tank has been reduced and sealed as follows:

- Vehicle fuel tanks shall not exceed one quarter of the tank capacity or 5 gallons (18.9 L) whichever is less
- All fuel tank openings shall be sealed in an approved manner to prevent escape of vapors (taped)
- The battery cables must be disconnected from the terminals and remain disconnected while the vehicle is inside the building. Loose cable ends must be taped to cover all the exposed metal
- No vehicle may be started or operated within any TCC building during show hours without approval of the Fire Inspector.
- Adding or removing fuel within any TCC building is prohibited. Fuel can be added outdoors, not under the canopy, in an approved location by the Fire Inspector. The use of special fuel blends inside the building is subject to approval by TFD.
- A vehicle key must be left in the Security Control Office for emergencies.

Fire protection shall be approved by TFD code official for motor vehicle shows/events. The level of protection required shall be determined for each event.





TEMPORARY PERMIT

INTERNAL COMBUSTION ENGINES USE

ISSUED DATE _____ **EVENT** _____

The Tucson Fire Code requires a permit for displaying an internal combustion engine for each motor vehicle, boat, aircraft or machinery. Display permit on passenger side window or dash.

The undersigned hereby agrees to abide by the Tucson Fire Code (TFC) as follows:

- 1) Fuel of any type shall be limited. Fuel, in fuel tanks, shall not exceed one quarter of a tank capacity or 5 gallons, whichever is less.
- 2) All fuel tank openings shall be sealed in an approved manner to prevent the escape of vapors.
- 3) Vehicles or equipment shall not be fueled or de-fueled within the building and only in approved location. Promoter shall provide spill containment materials and their proper disposal
- 4) The battery must be disconnected and remain disconnected while the vehicle is inside the building. Cable ends must be taped and all the exposed metal covered
- 5) LPG/CNG tanks shall be removed

	YES	NO
Visual Inspection for leaks		
Fuel Tank Sealed		
Keys on Site		
LPG Tank Removed		
Battery Disconnected, Leads Taped		
This Form Signed		

I certify that I have read the above Tucson Fire Code provisions and that any violation(s) will be grounds for possible civil infraction(s) and revocation of this permit. A revoked permit shall result in removal of the exhibit from the show floor immediately.

Exhibitor's Signature: _____ **Date:** _____

Contact Phone #'s: _____



Rates Effective Jan. 1, 2024-Dec. 31, 2025
Information & Online Ordering
www.commonwealthexpo.com



Submit Form To:

Commonwealth Electric Company
 260 South Church Ave, Tucson, AZ 85701
 PH 520.623.2155 Fax 520.623.3401
 Jennifer Sutherland
 CELL: 520.940.8377



jsutherland@commonwealthelectric.com

Please note that electrical orders can only be placed online or via this form, phone orders not accepted.

Event 2025 SWTA Annual Transit Conference & Expo		Dates February 19-20, 2025			
		Event # 499479			
For Discount Payment Price we must receive your order and payment prior to this DISCOUNT DEADLINE DATE OF: 02/03/2025					
Company Name		Booth			
Standard Electrical Outlets **Rates are for duration of event**		<p>If you require services not listed on this form please call for a quote.</p> <p>24 HOUR SERVICES: Rates are DOUBLE the Outlet Rate Check if required</p> <p>OVERHEAD POWER: Rates are Time and Material, please call for quote.</p> <p>208V and 480V SERVICES: There is a MINIMUM labor charge of (1) hr. for installation/removal of all 208V service. There is a MINIMUM labor charge of (2) hrs. for installation/removal of all 480V service.</p> <p>ELECTRICAL LABOR: Outlets requested to be placed anywhere other than the back of the booth will require a layout and a MINIMUM of (1) hour labor. Please call for quotes on labor if your booth is an Island booth or needs overhead power.</p> <p>Okay to proceed (layout with scaled orientation attached.) Order will be installed prior to exhibitor move in.</p> <p>Layout to follow</p>			
Qty	Description			Discount	Regular
120V Motor & Equipment Outlets (3 Pronged)					
	500 Watts			\$91.11	\$118.45
	1000 Watts			\$115.49	\$150.14
	2000 Watts			\$141.16	\$183.51
1 Phase 208V A.C. 60 Cycle **Requires MINIMUM (1) hr Labor					
	10 Amp 208V 1 Phase			\$159.13	\$206.86
	20 Amp 208V 1 Phase			\$189.92	\$246.90
	30 Amp 208V 1 Phase			\$232.27	\$301.95
	40 Amp 208V 1 Phase	\$302.85	\$393.71		
	50 Amp 208V 1 Phase	\$377.28	\$490.47		
	60 Amp 208V 1 Phase	\$449.14	\$583.89		
3 Phase 208V A.C. 60 Cycle **Requires MINIMUM (1) hr Labor					
	10 Amp 208V 3 Phase	\$206.61	\$268.59		
	20 Amp 208V 3 Phase	\$245.10	\$318.64		
	30 Amp 208V 3 Phase	\$302.85	\$393.71		
	40 Amp 208V 3 Phase	\$395.25	\$513.82		
	50 Amp 208V 3 Phase	\$491.49	\$638.94		
	60 Amp 208V 3 Phase	\$589.02	\$765.73		
Rental Items					
	Extension Cord 15'	\$28.66			
	Extension Cord 25'	\$32.39			
	5-way power strip	\$28.66			
	3-way adaptor	\$26.16			
In line booths with standard electrical placement (along back drapeline) will NOT incur labor charges					
Labor for Layout/Overhead/Qty and 208V Services					
	ST (M-F 8am-4:30pm)	\$85.00			
	OT (M-F 4:30pm-12am & Sat 8am-12am)	\$127.50			
	DT (M-Sat. 12am-8am & all Sun/Holidays)	\$170.00			
State of Arizona Tax Exempt Form 5000 must be submitted with order to receive exemption. **By signing the order form, I have read and agree to all of Commonwealth Electric Company's Conditions and Regulations.**		Total Order			
		8.7% Sales Tax			
		Labor Amount			
		Total Due			
FOR SUPERVISED LABOR ONLY					
Exhibitor supervision requested, requires a MINIMUM of (1) hour of labor.					
Date/Time Requested					
Onsite Contact					
Onsite Contact Cell #					
Company Name		Phone			
		Cell Phone			
Address		City	State Zip		
Email Address		Onsite Contact; Name & Number			
Signature		Print Name			
Paid by: CK AX MC VS	Credit Card Number	CVV	Exp Date		
Cardholder Signature		Print Name			

Payment Policy:

1. **Payment in full:** is required on all orders at the time the order is placed. Purchase orders are not considered payment. There will be an additional \$35 service charge on all returned checks. For your convenience, we accept the following forms of payment: Check, Visa, MasterCard and American Express. **No cash will be accepted.**
2. **Tax:** All amounts, except labor, are subject to a combined Arizona State and City sales tax. If you are tax exempt in the state of Arizona, please attach sales tax exemption certificate (form 5000) to your order. Orders submitted online will not be accepted as tax exempt, and credit will not be given for sales tax paid online. Tax exempt orders must be submitted with the order form and not placed online.
3. **Discount Rates:** Please see order form for exact date for each event.
4. **Regular Rates:** are applied to all orders received after the deadline for the discounted rates and orders received on-site at the event.
5. **Refunds:** will not be issued on services that have already been installed. Refunds will not be considered unless submitted in writing by customer prior to the close of the event.
6. **Contract Agreement:** Lessor will not be responsible for strikes, accidents, an Act of God, or delays beyond control. If by any reason of any default on the part of the lessee, hereunder, it becomes necessary to engage an attorney, the lessee agrees to pay all costs, expenses, and the attorney's fees expanded or incurred by lessor in connection therewith. Payment or receipt of this contract constitutes acknowledgment that lessee has read and agrees to all conditions and regulations as stated in this contract.

Outlets & Equipment:

1. All electrical outlets are provided at an additional charge and are not part of a booth package unless otherwise indicated on the Commonwealth Electric order form.
2. Each outlet ordered is ONE (1) SINGLE plug-in.
3. In-line and peninsula booths: each outlet will be located at the back of the booth. Island booths: outlets will be placed at the most convenient location for Commonwealth Electric unless otherwise noted by the customer. Should outlets be required in any other location within the booth, a labor charge will be incurred, and a layout must be submitted with order.
4. Outlets are to be ordered separately by each customer and may not be shared with other customers.
5. Building utility outlets are not a part of the booth space and are not to be accessed, blocked or used by customers.
6. Electrical floor boxes must not be covered or blocked by customer unless prior arrangements have been made with Commonwealth Electric.
7. All materials and equipment furnished by Commonwealth Electric for this service order, shall remain the property of Commonwealth Electric and shall only be removed by Commonwealth Electric at the close of the event. Any equipment removed by the customer shall be charged the replacement cost of the specific equipment.

Labor:

Labor charges shall be incurred for the following: (please refer to the order form or contact Commonwealth Electric for labor minimums per service)

- Request for your outlet to be placed anywhere other than the back of your booth. A layout must be attached to your order with booth orientation & dimensions.
- All 110V (120V) services above 20 amps.
- All 208V (220V) services ordered with a minimum of one (1) hour labor per connection.
- Conversion of customer power connection.
- All overhead services.
- Ordering eight (8) or more services within the same booth space.
- Requested customer supervision for service installation.

Conditions and Regulations:

1. Commonwealth Electric will provide standard NEMA connections for all services 208V (220V) or higher. Please check with Commonwealth Electric for specific type of connection per facility. It is the responsibility of each customer to convert to each facility's connection.
2. Customers are responsible for supplying all converters 220V-110V for international equipment. Should Commonwealth Electric supply, there will be an additional charge. Contact Commonwealth Electric for specific charges.
3. Commonwealth Electric will not be responsible for any cutting or altering of any floor covering in order to bring services to a booth in a specific location.
4. All equipment, regardless of source of power, must comply with all Federal, State, and City safety codes.
5. All equipment must be approved by Underwriters Laboratory and properly UL labeled with complete information as to current, voltage, phase, cycle, horsepower, etc. If equipment is not UL approved and tagged, Commonwealth Electric reserves the right to refuse to energize.
6. All customer supplied cords must be of the three (3) wire grounded type. Use of open sockets, latex or lamp cord wire is prohibited.
7. All exposed, non-current carrying metal parts of fixed equipment, which are liable to be energized, shall be grounded.
8. Commonwealth Electric is not responsible for voltage fluctuations or power failure because of temporary conditions.

FAQ:

1. How much power do I need to order?

Answer: You will need to check the electrical tag/sticker on each piece of equipment to determine the actual wattage or amperage required. Please feel free to contact the Commonwealth Electric Account Manager for your event if you need assistance.

2. How much power will I need to order for a laptop?

Answer: You may power up to three (3) laptops per 500-watt outlet ordered.

3. How much power will I need to order for lighting?

Answer: Please add up the wattage of each lightbulb to determine total amount of wattage needed to order. Example: Four (4) sixty (60) watt lightbulbs would total two hundred forty (240) watts. You would need to order a 500-watt outlet to power these lights.



Telephone & Internet Order Form

EVENT/CLIENT INFORMATION:

Name of Event: _____

Event Dates: _____ Location/Booth Number: _____

Name of Company: _____

Contact Name: _____

Address: _____

City, State and Zip Code: _____

Phone Number: _____ Email: _____

Describe Phone/Internet Needs: _____

Order: _____

TELEPHONE & INTERNET DETAILS:

Unit Cost: \$250 Phone Line

Unit Cost: \$35 Handset

Unit Cost: \$350 (1st Line) Wired Single Service Internet, no hubs or routers
\$200 (2nd Line), \$100 each (3 or more lines)

- Internet orders are per IP address.
- Static IP's and Gateways, please contact your Event Manager to place order.
- VPN's require advance notice and may incur additional charges.
- Accept Visa, MasterCard, American Express, and Discover. Please coordinate all check payments with Event Manager 10 days prior to the first schedule day of move in.

PAYMENT METHOD:

Please complete the top portion of the form and submit via email to:

janine.pfeifer@tucsonaz.gov

Once received, an email with a link to pay online via our secure payment processing portal will be sent to the email address provided. **Payment must be received 7 days prior to the first scheduled day of move in. Once payment is received, your Event Manager will process your order.**



2024 Exhibitor AV Order Form

SWTA Conference | Tucson Convention Center



EVCO360

Voice/Text: 501.626.8817 | Email: info@evco360.com | Web: evco360.com

EVCO360 proudly offers a wide range of technology to help enhance your booth or exhibit and attract attendees.

Allow us to help you stand out from the crowd!

Examples of equipment we offer include, but are not limited to:

- **TV Monitors (Floor-mount or table-mount) 32"-75"**
- **Computers**
- **LED accent lighting**
- **Sound systems**
- **Projection**
- **Special effects**
- **Plants**
- **...and more**



Scan the QR code to email us with your equipment needs or reach out via voice/text at 501.626.8817.