



1921 Bellamah NW  
Albuquerque, NM 87104  
t. 505.243.9889  
f. 505.243.8197  
www.cssabq.com

email us @  
esr@cssabq.com

**FOR YOUR INFORMATION**

## **CONVENTION SERVICES OF THE SOUTHWEST. INC.**

**2024 SWTA ANNUAL TRANSIT CONFERENCE & EXPO**  
**Cox Business Convention Center - Tulsa**  
**Tulsa, Oklahoma**  
**Monday, February 5 – Tuesday, February 6, 2024**

Dear Exhibitor:

**WELCOME!** CSS is pleased to be selected by show management to serve as your Official Service Contractor.

This Exhibitor Service Kit will assist you in planning for the show. In addition to important show information, we have included the necessary show service order forms. To help save you money, we have provided you with the opportunity to take advantage of advance order discounts.

When placing your order, please keep in mind:

- [On-Line Ordering](#) is available. Log-in information will be automatically emailed to the address on file with the association at the time of registration. If you do not receive the log-in, or are not the registered contact, please contact us at [esr@cssabq.com](mailto:esr@cssabq.com) or (505) 243-9889 to obtain one.
- Complete and return all order forms by the indicated discounted deadline date to avoid higher costs. Each form should be returned to the appropriate company and address listed on that form.
- Review our payment policy carefully. **CSS** requires payment in full at the time you place your order, along with a completed Credit Card Authorization form.
- Please include the prevailing sales tax in your order, **currently 9.4% in Tulsa, OK**. Sales tax is applicable to rentals. Labor, and material handling services are exempt in the state of Oklahoma. *(If you have a state or federal exemption, please include with forms at the time of ordering.)*

We will help you coordinate all your trade show needs including the shipment of all your trade show materials. For your inbound and outbound freight shipments, we offer the service of our preferred carrier **ArcBest (ABF Freight) 1-800-654-7019**.

We look forward to serving you from start to finish. We are here to make sure your experience is a complete success. If you need assistance or additional information, please contact our Exhibitor Service Department:

Email: [esr@cssabq.com](mailto:esr@cssabq.com)  
1921 Bellamah Ave. NW  
Albuquerque, NM 87104  
Phone: (505) 243-9889  
Fax: (505) 243-8197

Or visit us on the World Wide Web at <http://www.cssabq.com>.



1921 Bellamah NW  
 Albuquerque, NM 87104  
 t. 505.243.9889  
 f. 505.243.8197  
 www.cssabq.com

email us @  
 esr@cssabq.com

## SHOW INFORMATION QUICK REFERENCE

# CONVENTION SERVICES OF THE SOUTHWEST, INC.

<b>SHOW NAME:</b>	2024 SWTA Annual Transit Conference & Expo	
<b>VEHICLE MOVE-IN:</b>	Sunday, February 4, 2024	11:00AM - 3:00PM
<b>EXHIBITOR MOVE-IN:</b>	Sunday, February 4, 2024	3:00PM – 7:00PM
	Monday, February 5, 2024	8:00AM – 2:00PM
<b>SHOW DATE(S):</b>	Monday, February 5, 2024	3:45PM – 6:00PM ( <i>Reception</i> )
	Tuesday, February 6, 2024	9:30AM – 12:00PM ( <i>Coffee Break: 9:30AM – 10:00AM</i> )
	Tuesday, February 6, 2024	12:00PM – 2:00PM ( <i>Luncheon</i> )
<b>VEHICLE MOVE-OUT:</b>	Tuesday, February 6, 2024	2:00PM – 6:00PM
<b>EXHIBITOR MOVE-OUT:</b>	Tuesday, February 6, 2024	2:00PM – 6:00PM

Outside freight carriers must be checked in by: **Tuesday, February 06, 2024 @ 5:00PM**  
 All materials must be packed with bill(s) of lading turned in to **CSS** by: **Tuesday, February 06, 2024 @ 6:00PM**

**SHOW LOCATION:** Cox Business Convention Center - Tulsa  
 Exhibit Halls A&B  
 100 Civic Center  
 Tulsa, OK 74103

<b>STANDARD BOOTH PACKAGE:</b>	<b>10' x 10'</b>	
(Included with booth purchase)	8' Black/Terra Cotta Draped Back Wall	
	3' Black Draped Side Rail	
	(1) 6' Plum Draped Table	The exhibit hall <b>IS NOT</b> carpeted.
	(2) Molded Plastic Chairs	
	(1) Waste Basket w/ Liner	Aisle Carpet color is <b>Safari</b> .
	(1) 7" x 44" ID Sign	

**NOTE: Cox Business Convention Center REQUIRES a Vehicle Display Waiver to be submitted PER VEHICLE prior to allowing vehicles to be displayed on the show floor.**

**IMPORTANT DEADLINES:**

First date freight can arrive at the advance warehouse:	<b>Tuesday, January 02, 2024</b>
Submission deadline for exhibitor appointed contractor (EAC) notification:	<b>Tuesday, January 02, 2024</b>
Last date to receive certificate of insurance for EAC:	<b>Tuesday, January 02, 2024</b>
Advance Orders and Payment Deadline:	<b>Monday, January 15, 2024</b>
Last date freight can arrive at the advance warehouse:	<b>Thursday, February 01, 2024</b>
First date for direct shipments to facility:	<b>Sunday, February 04, 2024</b>

**NOTE: CSS will be closed on Monday, January 15, 2024.**

**SHIPPING INFORMATION:**

ADVANCE FREIGHT RECEIVING Monday – Friday 11:00AM – 4:00PM Tuesday, January 2 – Thursday, February 1, 2024 ADVANCE SHIPPING ADDRESS	
Ship To:	Exhibitor Name and Booth # <b>SWTA 2024</b> c/o <b>CSS</b> ABF Freight 4410 S. Jackson Tulsa, OK 74107

DIRECT FREIGHT RECEIVING Sunday, February 4, 2024 --- 8:00AM – 5:00PM Monday, February 5, 2024 --- 8:00AM – 12:00PM DIRECT SHIPPING ADDRESS	
Ship To:	Exhibitor Name and Booth # c/o <b>CSS</b> <b>SWTA 2024</b> Cox Business Convention Center – Exhibit Halls A&B 100 Civic Center Tulsa, OK 74103



1921 Bellamah NW  
 Albuquerque, NM 87104  
 t. 505.243.9889  
 f. 505.243.8197  
 www.cssabq.com

email us @  
 esr@cssabq.com

# CREDIT CARD AUTHORIZATION ORDER SUMMARY FORM TERMS AND CONDITIONS ACCEPTANCE

## CONVENTION SERVICES OF THE SOUTHWEST, INC.

Event Name: <b>SWTA 2024</b>	Advance Payment Deadline: <b>Monday, January 15, 2024</b>	Booth # (s):
Company Name:	Telephone #:	
Billing Address:	Fax #:	
City/State/Zip:	Email Address:	
Authorized by:		

**CREDIT CARD CHARGE AUTHORIZATION**

Please complete the information requested below and return this form with your order(s). Any show site balances or charges for outbound labor, freight or miscellaneous items not paid before show closing will be charged to your credit card account. Your signature below acknowledges understanding and acceptance of the terms detailed in the CSS Payment Policy, the CSS Material Handling Information and Limits of Liability, and the CSS Conditions and Regulations for electrical usage provided with your Service Kit. Acceptance of CSS' payment policy, material handling terms and conditions, and limits of liability will be construed when any of the following conditions are met: This Credit Card Authorization is signed, the Material Handling Agreement (MHA) is signed; Exhibitor's materials are delivered to CSS's warehouse or to an event site for which CSS is the Official Show Contractor; or an order for labor and/or rental equipment is placed by Exhibitor with CSS. **The Estimated Total below may not necessarily reflect the final total charged to your credit card at close of show.** (There will be a \$75.00 administrative fee if a credit card dispute is filed and CSS is awarded charges.)

**Account #:**

**Expiration Date:**     **Billing Zip Code:**

**Card Verification # (3 or 4 Digit Code on Card):**

Cardholder Signature
Cardholder Name (please print)

CSS ORDER FORMS	AMOUNT DUE
Furnishings	
Upgrade Furnishings	
Carpet / Prestige Carpet	
Rental Display	
Labor	
Vehicle Spotting	
Rigging	
Material Handling	
Cleaning	
Floral	
Signs/Graphics	
<b>Information included but ordered from a different location</b>	
Facility Services (Electrical, Internet, Catering, Utilities)	XXXXXXXX
Audio Visual	XXXXXXXX
<b>Estimated Total</b> (includes State Tax where applicable)	

Using the order forms, remember to include and transfer the sales tax into the estimated grand total above.  
**This form is intended as a tool to assist you and is not a replacement for any other form.**



1921 Bellamah NW  
Albuquerque, NM 87104  
t. 505.243.9889  
f. 505.243.8197  
www.cssabq.com

email us @  
esr@cssabq.com

## PAYMENT POLICY

# CONVENTION SERVICES OF THE SOUTHWEST, INC.

### ADVANCE PRICING

To obtain the advance pricing, full payment must be included with your order. Orders received after the advance payment deadline date or made at the Exhibitor Service Center during the show, will be billed at the "Standard Price" as listed on the enclosed forms. **Telephone orders will not be accepted.**

### PAYMENT OPTIONS

We offer two convenient ways for you to order and pay for your show services provided by **CSS**.

1. Service Kit (pdf download)
  - a. Advance payment by **Company Check, Wire Transfer, or e-check**: All checks for show services provided by **CSS** should be made payable to **Convention Services of the Southwest, Inc. (CSS)** and must be in U.S. Dollars drawn on a U.S. bank. International exhibitors must prepay all balances no later than the advanced payment deadline in U.S. Dollars drawn on U.S. banks. A **Credit Card Authorization** form is also required to cover any variances with regards to drayage (material handling) and labor orders as well as any additional charges incurred at show site.
    - i. Please note that for Wire Transfer/ACH payments, **CSS** does not pay bank fees from the sending or receiving bank. Please add \$25.00 to amounts transferred to be considered paid in full.
    - ii. **CSS** will add a fee of \$35.00 to any order where the check payment is returned as insufficient funds.
  - b. **Credit Card**: For your convenience we accept Visa, MasterCard, and American Express. You must complete the **Credit Card Authorization** form. For discount rates to apply, **CSS** must receive this form by **Monday, January 15, 2024**. *(There will be a \$75.00 administrative fee if a credit card dispute is filed and CSS is awarded charges.)*
2. **On-Line Ordering**
  - a. Log-in information with a temporary password will be automatically emailed to the email address on file with the association at the time of registration. To place your order, log-in and follow the instructions. A credit card on file is required to complete your order. An email will be sent confirming your order is complete. The charges on your confirmation will not be considered final until the show closes *(drayage fees are added once freight is received and floor orders may be added)*.

### PAYMENT TERMS

**To process your order for services and materials listed in this Exhibitor Service Kit, we must have your completed and signed Credit Card Authorization form or full payment in advance or you must place your order on-line.** Invoices for outstanding balances will be emailed to the email address on file and must be paid before the end of the event. If you have any concerns about your charges, please stop by the Exhibitor Service Center at the show. **Charges may not be disputed after the show.**

**Items ordered and delivered but subsequently canceled will be charged 50% of the order price to cover labor involved.**

**Please notify your company representative who will be at the show site of our payment policy. Your cooperation is appreciated. No credits will be issued after close of show.**

If a display house represents the exhibiting company, the exhibiting company is ultimately responsible for payment of all costs incurred on its behalf. (See **Third Party Payment Form**). **Third Parties must contact CSS for an on-line log in.**





1921 Bellamah NW  
 Albuquerque, NM 87104  
 t. 505.243.9889  
 f. 505.243.8197  
 www.cssabq.com

email us @  
 esr@cssabq.com

## THIRD PARTY PAYMENT FORM

# CONVENTION SERVICES OF THE SOUTHWEST. INC.

CSS will present show site invoices to third parties for payment of services rendered to exhibitors, provided the following conditions are met:

- The payment record of the third party is acceptable to **CSS**.
- This completed form is to be signed by **BOTH PARTIES** and returned to **CSS** by **Monday, January 15, 2024**.
- This form is to be accompanied by a completed **Credit Card Authorization** form from **EACH PARTY**.
- If there is any doubt which party is to be invoiced for a service, **the exhibiting firm accepts responsibility for payment upon presentation of invoice at show site**.
- The **exhibiting firm** is ultimately responsible for payment of all charges by show close.

Please indicate below which items/services are to be invoiced to the third party:

Furniture/Carpet     
  Booth Cleaning     
  Material Handling     
  Booth Labor

Other:

WE UNDERSTAND AND AGREE THAT WE, THE EXHIBITING COMPANY, ARE ULTIMATELY RESPONSIBLE FOR PAYMENT OF CHARGES INCURRED. IN THE EVENT THE NAMED THIRD PARTY DOES NOT MAKE PAYMENT UPON PRESENTATION OF INVOICE AT SHOW SITE, SUCH CHARGES WILL BE PRESENTED TO THE EXHIBITING COMPANY FOR PAYMENT BEFORE THE CLOSE OF THE SHOW.

Event Name: <b>SWTA 2024</b>	Booth #:
Exhibiting Company:	Display House 3rd Party:
Address:	Address:
City/State/Zip:	City/State/Zip:
Telephone #:	Telephone #:
Fax #:	Fax #:
Email address:	Email address:
Authorized Signature:	Authorized Signature:
Print Name & Title:	Print Name & Title:



1921 Bellamah NW  
 Albuquerque, NM 87104  
 t. 505.243.9889  
 f. 505.243.8197  
 www.cssabq.com

email us @  
 esr@cssabq.com

# FURNISHINGS ORDER FORM

## CONVENTION SERVICES OF THE SOUTHWEST, INC.

Event Name: <b>SWTA 2024</b>	Advance Payment Deadline: <b>Monday, January 15, 2024</b>	Booth # (s):
Company Name:	Telephone #:	
Billing Address:	Fax #:	
City/State/Zip:	Email Address:	
Authorized by:		

### DRAPED DISPLAY TABLES - 30" HIGH (choose skirt color below)

Quantity	Description	Advance Price	Standard Price
	4'L X 30"H Draped Table	164	196
	6'L X 30"H Draped Table	184	220
	8'L X 30"H Draped Table	214	257

### DRAPED DISPLAY COUNTERS - 40" HIGH (choose skirt color below)

	4'L X 40"H Draped Counter	187	224
	6'L X 40"H Draped Counter	225	270
	8'L X 40"H Draped Counter	246	295
	30"D X 40"H Spandex Round Highboy	211	253

### UNDRAPED DISPLAY TABLES - 30" HIGH

	4'L X 30"H Undraped Table	94	113
	6'L X 30"H Undraped Table	108	129
	8'L X 30"H Undraped Table	137	164
	30"H Conference Table (circle choice) 36"D Black 36" D White 40"D Grey	295	354

### UNDRAPED DISPLAY COUNTERS - 40" HIGH

	4'L X 40"H Undraped Counter	108	129
	6'L X 40"H Undraped Counter	125	150
	8'L X 40"H Undraped Counter	143	172
	40"H Conference Counter (circle choice) 36"D Black 36" D White 40"D Grey	316	378

### TABLE SKIRTING (choose skirt color below)

	4th Side Table Drape for Table 30"H	92	111
	4th Side Table Drape for Counter 40"H	108	130
	Individual Table Skirt for Table 30"H	111	133
	Individual Table Skirt for Counter 40"H	128	154

### SPECIAL DRAPERY (6' minimum) (choose drape color below)

	3' High Drapery/linear ft.	14	18
	8' High Drapery/linear ft.	24	28
	3' Upright w/ 1/2 Base	26	30
	8' Upright w/ Full Base	27	32
	Crossbar	27	32

### STANDARD FURNITURE AND ACCESSORIES

	Grey Molded Plastic Chair	72	84
	Padded Side Chair	96	113
	Padded Arm Chair	105	122
	Upholstered Bar Stool with Back	118	138
	Bag Rack (circle choice) "T" waterfall	94	106
	Literature Rack (circle choice) flat accordion	223	249
	Aluminum Easel	44	49
	Wastebasket with Liner	30	34
	Fishbowl	42	47
	4' x 8' Board* Peg Board or Poster Board (circle choices) Horizontal or Vertical	204	245
	36" x 48" Double Sided Magnetic Whiteboard	204	245
	4'L X 7"H Table Riser (draped in vinyl)	79	95
	6'L X 7"H Table Riser (draped in vinyl)	103	110
	Glass Show Case (48"W x 18"D x 38"H w/lock and light)	443	Contact for Quote

\*Maximum load on boards is 50 lbs. Poster Boards are black & Velcro/push pin "friendly".

#### SKIRT AND DRAPE COLOR CHOICES (please circle choice)

Blue Gold Teal Beige Hunter Green  
 Black White Peach Burgundy Terra-Cotta  
 Red Silver Plum Willow

#### SPANDEX COLOR CHOICES (please circle choice)

Red Black Blue  
 White Teal Silver

### PLEASE READ PAYMENT POLICY

SUBTOTAL	\$
Tax (9.4%)	\$
<b>TOTAL</b>	<b>\$</b>



1921 Bellamah NW  
 Albuquerque, NM 87104  
 t. 505.243.9889  
 f. 505.243.8197  
 www.cssabq.com

email us @  
 esr@cssabq.com

# STANDARD FURNISHINGS

## CONVENTION SERVICES OF THE SOUTHWEST, INC.



**DRAPED TABLE**  
 2' W X (4', 6', OR 8' L) X 30" H



**DRAPED COUNTER**  
 2' W X (4', 6', OR 8' L) X 40" H



**UNDRAPED TABLE/COUNTER**  
 2' W X (4', 6', OR 8' L) X 30" H OR 40" H



**SPANDEX HIGHBOY**  
 30" D X 40" H



**ROUND CONFERENCE TABLE/COUNTER**  
 36" D (BLACK/WHITE) or  
 40" D (GREY) x 30" or 40" H

### DRAPE COLORS

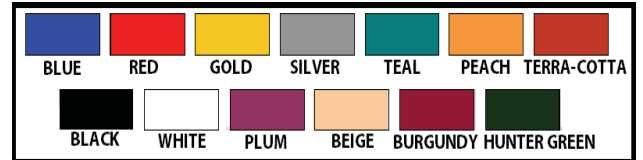

### SPANDEX COLORS

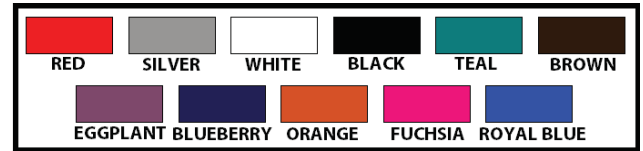

**MOLDED PLASTIC CHAIR**



**PADDED SIDE CHAIR**



**PADDED ARM CHAIR**



**UPHOLSTERED BAR STOOL**



1921 Bellamah NW  
Albuquerque, NM 87104  
t. 505.243.9889  
f. 505.243.8197  
www.cssabq.com

email us @  
esr@cssabq.com

## STANDARD FURNISHINGS

### CONVENTION SERVICES OF THE SOUTHWEST, INC.



T STYLE BAG RACK  
50" H X 15" W X 12" L



WATERFALL BAG RACK  
50" H X 15" W X 12" L



ALUMINUM EASEL  
64" H X 32" W X 32" L



FLAT LITERATURE STAND WITH 6  
POCKETS  
55" H X 14" W X 9" L



ACCORDION LITERATURE  
STAND  
5' HIGH



IPAD STAND WITH ADJUSTABLE  
POLE (28" - 44")  
BASE 18" X 14"

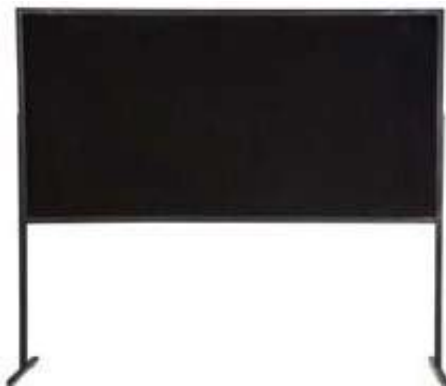

POSTER BOARD  
(HORIZONTAL)  
4' X 8'



WHITEBOARD (VERTICAL)  
36"W X 48"H + FRAME



GLASS SHOW CASE  
38" H X 48" W X 18" D



1921 Bellamah NW  
 Albuquerque, NM 87104  
 t. 505.243.9889  
 f. 505.243.8197  
 www.cssabq.com

email us @  
 esr@cssabq.com

# UPGRADE FURNISHINGS ORDER FORM

## CONVENTION SERVICES OF THE SOUTHWEST, INC.

Event Name: <b>SWTA 2024</b>	Advance Payment Deadline: <b>Monday, January 15, 2024</b>	Booth # (s):
Company Name:	Telephone #:	
Billing Address:	Fax #:	
City/State/Zip:	Email Address:	
Authorized by:		

Note: Due to limited quantities on many items, a comparable product may be substituted.  
 Please contact **CSS** for quantity availabilities.

### UPGRADE CHAIRS

Quantity	Description	Dimensions	Color (please circle)	Price
	Jetson Chair	15" x 15" w/ adjustable seat	White Black	195
	Leather Office Chair w/ Mesh Back	34.7"H x 22.75"W x 24"D	Black Only	162
	Mesh Steno Chair w/ Wheels	38.5-42.2"H x 27.1"W x 26.7"D	Black Only	195
	Modern Chair	33.5"H x 18.8"W x 18.8"D	White Only	162
	Soda Fountain Barstool	30"H x 17"W x 17"D	Red Black	162
	Swivel Barstools w/ Curved Back	32.5"H x 22.5"W x 18"D	White Black	227

### UPGRADE TABLES

	24" Bistro Table	23.75" - 42"H x 24"W x 24"D	White Black	259
	31" Glass Table	29"H x 31.5"W x 31.5"D		290
	Glass End Table	15"H x 23"W x 23"D	Chrome Black	195
	Glass Coffee Table	15.8"H x 39.4"W x 19.7"D	Chrome Black	227
	Rectangular Conference Table	30"H x 36"W x 60"D		1034
	Triangle Glass Top Table	35"H x 35"W x 35"D		290

### UPGRADE SEATING

	Barrel Chair	29"H x 28"W x 29"D	Black Only	355
	White Executive Side Chair	35.25"H x 26.5"W x 23"D	White Only	306
	Chrome Leather Accent Chairs	30.5"H x 30.5"W x 27.5"D	White Black	453
	Chrome Leather Chair	32"H x 36"W x 33"D	White Only	585
	Chrome Leather Sofa	32"H x 81"W x 33"D	White Only	936
	Futon Lounger	32"H x 71"W x 34"D	Vanilla Only	549

**\*\*REFUNDS ON UPGRADE FURNISHINGS ARE NOT AVAILABLE AFTER THE ADVANCE ORDER DEADLINE DATE ABOVE\*\***

Please contact **CSS** for custom/specialty items not listed on this order form.

**PLEASE READ PAYMENT POLICY**

SUBTOTAL	\$
Tax (9.4%)	\$
<b>TOTAL</b>	<b>\$</b>



1921 Bellamah NW  
 Albuquerque, NM 87104  
 t. 505.243.9889  
 f. 505.243.8197  
 www.cssabq.com

email us @  
 esr@cssabq.com

# UPGRADE FURNISHINGS

## CONVENTION SERVICES OF THE SOUTHWEST, INC.



LEATHER OFFICE CHAIR  
 WITH MESH BACK  
 34.75" H x 22.75" W x 24" D



WHITE  
 MODERN CHAIR  
 33.5" H x 18.8" W x 18.8" D



MESH STENO CHAIR  
 w/ WHEELS  
 38.5-42.2" H x 27.1" W x 26.7" D



SODA FOUNTAIN  
 BARSTOOL  
 30" H x 17" W x 17" D  
 (Available w/ black  
 or red seat)



SWIVEL BARSTOOLS  
 WITH  
 CURVED BACK  
 32.5" H x 22.5" W x 18" D  
 (Available in  
 black and white)



(Available  
 in black  
 or white)

24" BISTRO TABLE shown with JETSON CHAIRS 15"x15" (adjustable seat) – rented separately  
 White – 23.75" D x 26.25" – 35.75" H (adjustable) – Black – 24" D x 42" H





1921 Bellamah NW  
 Albuquerque, NM 87104  
 t. 505.243.9889  
 f. 505.243.8197  
 www.cssabq.com

email us @  
 esr@cssabq.com

# UPGRADE FURNISHINGS

## CONVENTION SERVICES OF THE SOUTHWEST, INC.



**RECTANGULAR CONFERENCE TABLE**  
 30" H x 36" W x 60" D



**TRIANGLE GLASS TOP TABLE**  
 35" H x 35" W x 35" D



**31" ROUND GLASS TOP TABLE**  
 29" H x 31.5" D



**GLASS END TABLE E**  
 (Available in chrome or black)  
 15" H x 23" W x 23" D



**GLASS COFFEE TABLE** (Available in chrome or black)  
 15.8" H x 39.4" W x 19.7" D



**BLACK LEATHER BARREL CHAIR**  
 29" H X 28" W X 29"



**WHITE EXECUTIVE SIDE CHAIR**  
 35" H X 26" W X 23"



**CHROME LEATHER ACCENT CHAIR**  
 30.5" H X 30.5" W 27.5" D



**WHITE AND CHROME SOFA**  
 32" H X 81" W 33" D



**WHITE AND CHROME CHAIR**  
 32" H X 80" W 33" D



**VANILLA FUTON LOUNGER**  
 32" H X 71" W 34" D





1921 Bellamah NW  
Albuquerque, NM 87104  
t. 505.243.9889  
f. 505.243.8197  
www.cssabq.com

email us @  
esr@cssabq.com

# CARPET ORDER FORM

## CONVENTION SERVICES OF THE SOUTHWEST, INC.

Event Name: <b>SWTA 2024</b>	Advance Payment Deadline: <b>Monday, January 15, 2024</b>	Booth # (s):
Company Name:	Telephone #:	
Billing Address:	Fax #:	
City/State/Zip:	Email Address:	
Authorized by:		

### STANDARD CARPET

Quantity	Description	Advance Price	Standard Price
	10' x 10' carpet	211	254
	10' x 20' carpet	368	446
	10' x 30' carpet	553	665
	10' x 40' carpet	739	887
	SPECIAL CUT STANDARD CARPET (Carpet rolls are 10' wide, so special cut would be required for sizes smaller than 10' wide or a length other than in a 10' increment.)	\$4.07 per sq. ft.	\$4.88 per sq. ft.
	Visqueen	\$1.36 per sq. ft.	\$1.64 per sq. ft.
	Carpet Padding (100 sq. ft. min)	\$2.01 per sq. ft.	\$2.42 per sq. ft.

### STANDARD CARPET COLOR *(please circle color choice)*

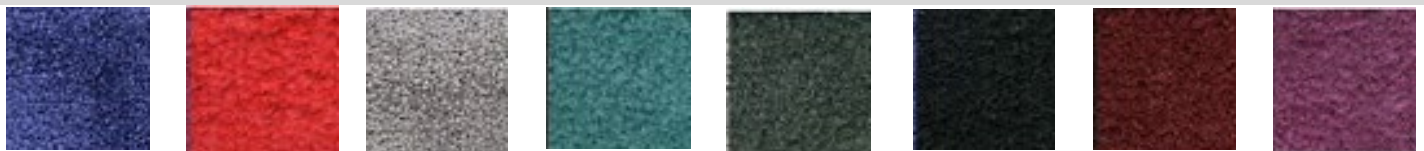

Blue      Red      Grey      Teal      Hunter Green      Black      Burgundy      Plum

### PAYMENT IN FULL MUST ACCOMPANY YOUR ORDER.

For your convenience, MasterCard, American Express, and Visa credit cards will be accepted.

### NO TELEPHONE ORDERS WILL BE ACCEPTED.

**\*\*All utility lines must be installed before carpet installation. Utilities should be ordered in advance. \*\***

### PLEASE READ PAYMENT POLICY

SUBTOTAL	\$
Tax (9.4%)	\$
<b>TOTAL</b>	<b>\$</b>



1921 Bellamah NW  
 Albuquerque, NM 87104  
 t. 505.243.9889  
 f. 505.243.8197  
 www.cssabq.com

email us @  
 esr@cssabq.com

# PRESTIGE CARPET ORDER FORM

## CONVENTION SERVICES OF THE SOUTHWEST, INC.

Event Name: <b>SWTA 2024</b>	Advance Payment Deadline: <b>Monday, January 15, 2024</b>	Booth # (s):
Company Name:	Telephone #:	
Billing Address:	Fax #:	
City/State/Zip:	Email Address:	
Authorized by:		

**\*\*\*\* ORDERS PLACED AFTER THE ABOVE DEADLINE DATE, PLEASE CALL FOR AVAILABILITY AND LATE FEES \*\*\*\***

### SPECIAL CUT PRESTIGE CARPET

Enhance your exhibit with 30 oz. plush, heavy-cut polyester pile carpet

Carpet Size \_\_\_\_\_ x \_\_\_\_\_ = \_\_\_\_\_ square feet x \$5.35 = \$ \_\_\_\_\_ TOTAL

### PRESTIGE CARPET COLOR (please circle color choice)

Pink	Magenta	Cherry Red	Red Fire	Cherry Blossom	Hay Loft	Navel
Orange	Butter Cream	Sunshine	Lime Green	Wintergreen	Pine	Forest
Pacific	Orion Blue	Lite Blue	Nautical	Caribbean	Process Blue	Bright Blue
Atlantic	Reflex Blue	Blueberry	Intense Blue	Deep Blue	Navy	Purple
Cream	Vanilla	Snowflake	White	Aluminum	Flannel	Fog
Tanium	Silver Mist	Grey Blue	Medium Grey	Cool Grey	Steel	Charcoal
Grey	English Grey	Smokey	Smoke	Black		

**Visqueen** is available at **\$1.36** (advanced price) or **\$1.64** (standard price) per square foot installed

\_\_\_\_\_ x \_\_\_\_\_ = \_\_\_\_\_ square feet x \$1.36 or \$1.64 = \$ \_\_\_\_\_ TOTAL

**Carpet Padding** is available at **\$2.01** (advanced) or **\$2.42** (standard) per square foot installed (100 sq. ft. min charge)

\_\_\_\_\_ x \_\_\_\_\_ = \_\_\_\_\_ square feet x \$2.01 or \$2.42 = \$ \_\_\_\_\_ TOTAL

**\*\*NO REFUNDS ON SPECIAL ORDER CARPET – ALL SALES ARE FINAL\*\***

Carpet Samples are available upon request – please fill out the mailing information below.

Mail Photo to:	_____
Attention:	_____
Company:	_____
Address:	_____
City:	_____ State: _____ Zip Code: _____
Phone Number:	_____

### PAYMENT IN FULL MUST ACCOMPANY YOUR ORDER.

For your convenience, MasterCard, American Express, and Visa credit cards will be accepted.

**NO TELEPHONE ORDERS WILL BE ACCEPTED.**

**\*\*All utility lines must be installed before carpet installation. Utilities should be ordered in advance. \*\***

**PLEASE READ PAYMENT POLICY**

SUBTOTAL	\$
Tax (9.4%)	\$
<b>TOTAL</b>	<b>\$</b>



1921 Bellamah NW  
Albuquerque, NM 87104  
t. 505.243.9889  
f. 505.243.8197  
www.cssabq.com

email us @  
esr@cssabq.com

# PRESTIGE CARPET COLORS

## CONVENTION SERVICES OF THE SOUTHWEST, INC.



PINK



MAGENTA



CHERRY RED



RED FIRE



CHERRY  
BLOSSOM



HAY LOFT



NAVEL



ORANGE

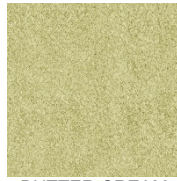

BUTTER CREAM

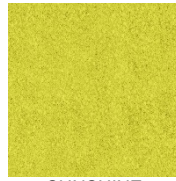

SUNSHINE



LIME GREEN

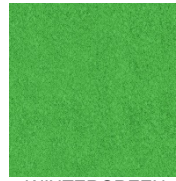

WINTERGREEN

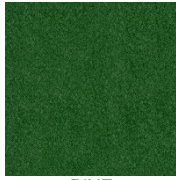

PINE



FOREST

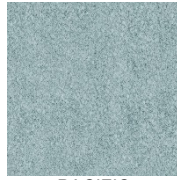

PACIFIC

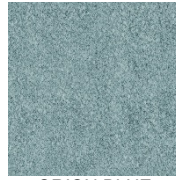

ORION BLUE

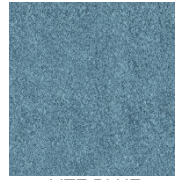

LITE BLUE

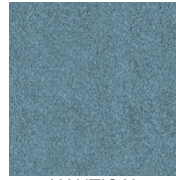

NAUTICAL

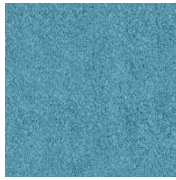

CARIBBEAN

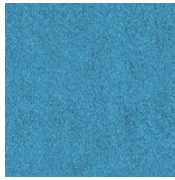

PROCESS BLUE

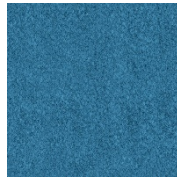

BRIGHT BLUE

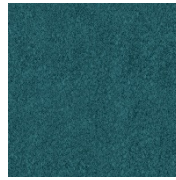

ATLANTIC

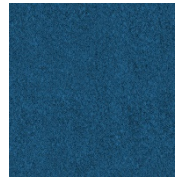

REFLEX BLUE

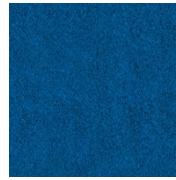

BLUEBERRY

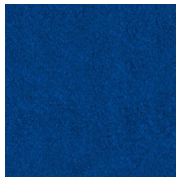

INTENSE BLUE



DEEP BLUE



NAVY



PURPLE



CREAM



VANILLA

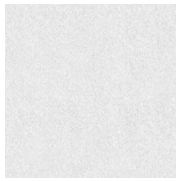

SNOWFLAKE

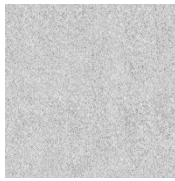

WHITE

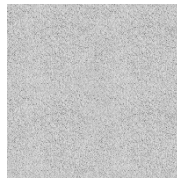

ALUMINUM



FLANNEL

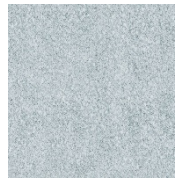

FOG

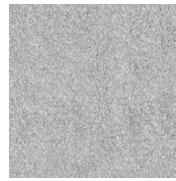

TITANIUM

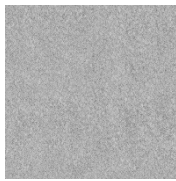

SILVER MIST



GREY BLUE

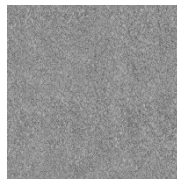

MEDIUM GREY

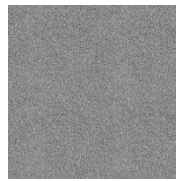

COOL GREY

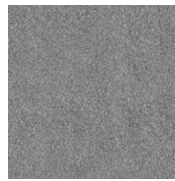

STEEL

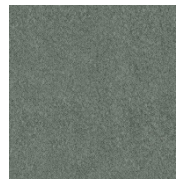

CHARCOAL

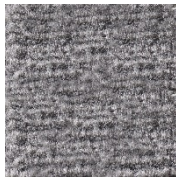

GREY

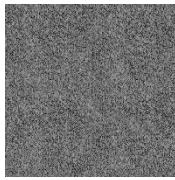

ENGLISH GREY

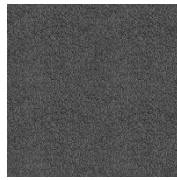

SMOKEY

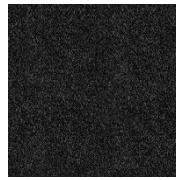

SMOKE



BLACK





1921 Bellamah NW  
 Albuquerque, NM 87104  
 t. 505.243.9889  
 f. 505.243.8197  
 www.cssabq.com

email us @  
 esr@cssabq.com

# RENTAL DISPLAY

## CONVENTION SERVICES OF THE SOUTHWEST, INC.

Event Name: <b>SWTA 2024</b>	Advance Payment Deadline: <b>Monday, January 15, 2024</b>	Booth # (s):
Company Name:	Telephone #:	
Billing Address:	Fax #:	
City/State/Zip:	Email Address:	
Authorized by:		

### Rental Display Units

Please contact CSS Exhibitor Services Department to order Rental Display Units at

Email: [esr@cssabq.com](mailto:esr@cssabq.com)

Or

Phone: (505) 243-9889

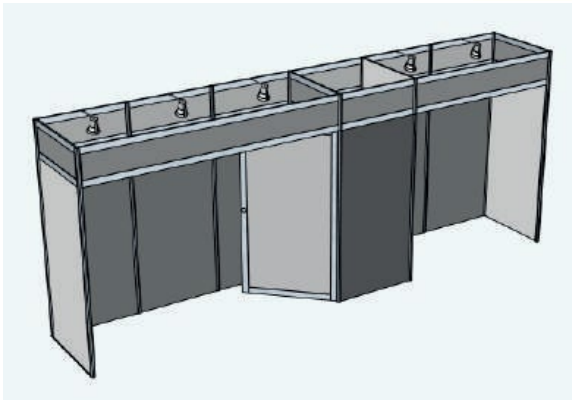
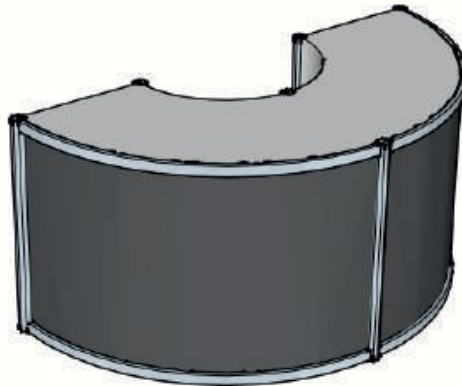
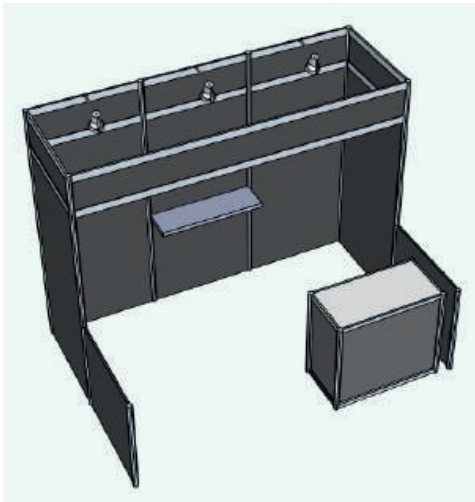



1921 Bellamah NW  
 Albuquerque, NM 87104  
 t. 505.243.9889  
 f. 505.243.8197  
 www.cssabq.com

email us @  
 esr@cssabq.com

# LABOR ORDER FORM

## CONVENTION SERVICES OF THE SOUTHWEST, INC.

Event Name: <b>SWTA 2024</b>	Advance Payment Deadline: <b>Monday, January 15, 2024</b>	Booth # (s):
Company Name:	Telephone #:	
Billing Address:	Fax #:	
City/State/Zip:	Email Address:	
Authorized by:		

Display labor & Forklift will be billed in 1/2 hour increments with a **one-hour minimum**.

DISPLAY LABOR RATES	Advance Price Per Person / Per Hour	Standard Price Per Person / Per Hour
Straight time – 8:00AM – 4:30PM (Weekdays)	\$121.00	\$145.00
Overtime – Before 8:00AM and after 4:30PM (Weekdays & Saturdays)	\$171.00	\$195.00
Sundays and Holidays	\$221.00	\$245.00

FORKLIFT RATES WITH OPERATOR	Advance Price Per Person / Per Hour	Standard Price Per Person / Per Hour
Straight time – 8:00AM – 4:30PM (Weekdays)	\$216.00	\$259.00
Overtime – Before 8:00AM and after 4:30PM (Weekdays & Saturdays)	\$266.00	\$309.00
Sundays and Holidays	\$316.00	\$359.00

**\*\*Exhibitor must contract all forklift operation with the official service contractor.\*\***

### SUPERVISION OF ALL LABOR IS REQUIRED. PLEASE INDICATE SUPERVISION PLAN:

#### PLAN A - EXHIBITOR SUPERVISION

All work is performed under the supervision of the Exhibitor. Starting time can be guaranteed only in those instances where persons are requested for the start of the working day, 8:00AM. If labor is not picked up or canceled without 24-hour's notice, your estimated labor hours will be charged. **The exhibitor must check in at the service desk to pick up labor ordered and check labor out at the service desk, upon completion of the work. If display materials have not arrived by scheduled labor install times, your estimated labor hours will be charged.**

Representative Name/Company
-----------------------------

#### PLAN B – CSS SUPERVISION

\*\*\*Please fill out all outbound shipping information.

All work is performed under the direction of **CSS** personnel. Our charge for this service is 30% of your total labor bill (**\$50 minimum**). In order to complete the work without your representative present, we must have set-up instructions (blueprints/floor plans, etc.). **If display materials have not arrived by scheduled labor install times, your estimated labor hours will be charged. You must also include outbound shipping labels and shipping instructions with your labor order.**

#### Please complete this section:

	Labor Type	No. of People	Date	Time	Approximate Hours	Estimated Cost
INSTALLATION						
DISMANTLE						

### PLEASE READ PAYMENT POLICY

SUBTOTAL	\$
Tax Exempt	\$ -----
<b>TOTAL</b>	<b>\$</b>



1921 Bellamah NW  
 Albuquerque, NM 87104  
 t. 505.243.9889  
 f. 505.243.8197  
 www.cssabq.com

email us @  
 esr@cssabq.com

**EXHIBITOR APPOINTED CONTACTOR (EAC)**  
 Submission Deadline for Notification & Certificate of Insurance: **Tue. January 2, 2024**

**CONVENTION SERVICES OF THE SOUTHWEST. INC.**

**EXHIBITORS WHO CHOOSE TO HAVE AN EXHIBIT SERVICE FIRM (OTHER THAN THE OFFICIAL LABOR CONTRACTOR) SUPERVISE LABOR, UNPACK, ERECT, ASSEMBLE, DISMANTLE, AND PACK DISPLAYS / EQUIPMENT MUST ABIDE BY THE FOLLOWING:**

- Exhibitor must notify Show Management and Convention Services of the Southwest (**CSS**) in writing no later than **Tuesday, January 2, 2024**.
- Exhibitor must ensure their contractor (EAC) provides **CSS** with a Certificate of Insurance indicating a minimum of \$1,000,000 liability coverage, including property damage, and naming **CSS** as additional insured by **Tuesday, January 2, 2024**. If this certificate is not received by the deadline date, Exhibitor may send in a supervisor only and will be required to order show labor. If **CSS** does not receive a certificate by move-in, the EAC will not be permitted on the show floor.
- Exhibitor is ultimately responsible for all services in connection with their exhibit, including freight, drayage, rentals, labor, etc. Companies who leave garbage in aisles or have excessive giveaway boxes will be mandated daily cleaning.
- The EAC must have all business licenses, permits, and Workers' Compensation insurance required by the State and/or City governments and the facility management prior to beginning work. The EAC shall provide evidence of compliance upon request, and must be compliant with all union jurisdictions.
- The EAC shall share with **CSS** all reasonable costs incurred as a result of/relating to the EAC's operation, including overtime pay for stewards, restoration of exhibit space to its initial condition, trash removal, etc.
- The EAC must provide **CSS** and Show Management the names of all personnel who will be working on the show floor. All personnel are required to wear identification badges at all times and shall comply with all facility badging requirements. Anyone without proper ID will be asked to leave the show floor.
- The EAC may not, under any circumstances solicit business on the show floor.
- The EAC must confine its operations to the exhibit area of its clients; no service desk, storage areas, or other work facilities shall be located within the building. (*Show aisles and public space are not part of the booth area.*)
- Upon request, the EAC shall provide evidence that it possesses applicable and current labor contracts and must comply with all collective bargaining regulations and agreements.
- The Official Contractor has total control over such services as electrical, plumbing, telephone, cleaning, drayage, etc. Exhibitors shall provide only the material they own and is to be used in their exhibit space.

NAME OF EXHIBITOR APPOINTED CONTRACTOR:	
ADDRESS:	
CONTACT, TELEPHONE # & FAX:	

The EAC must notify **CSS** of the names of all exhibiting companies for whom they have orders and the names of all employees working for them on the show floor. All EACs must provide insurance certificates to **CSS** and Show Management of the exhibition. Please list show name, location, and Exhibitor name on Certificate of Insurance. **Exhibitor Appointed Contractors will not have access to the show floor without a Certificate of Insurance on file with CSS.**

COMPANY:	BOOTH:
ADDRESS:	CONTACT NAME:
CITY:	SIGNATURE:
STATE: ZIP:	PHONE:
EMAIL:	FAX:

**SWTA 2024**



1921 Bellamah NW  
 Albuquerque, NM 87104  
 t. 505.243.9889  
 f. 505.243.8197  
 www.cssabq.com

email us @  
 esr@cssabq.com

# VEHICLE SPOTTING ORDER FORM

Mobile Units / Motorized Vehicles

## CONVENTION SERVICES OF THE SOUTHWEST, INC.

Event Name: <b>SWTA 2024</b>	Advance Payment Deadline: <b>Monday, January 15, 2024</b>	Booth # (s):
Company Name:	Telephone #:	
Billing Address:	Fax #:	
City/State/Zip:	Email Address:	
Authorized by:		

### DIRECT MOBILE UNITS / MOTORIZED VEHICLES / EXHIBIT AREA

Exhibitors or agents with mobile or motorized equipment will require guidance to their respective booths. This guidance is required and provided by **CSS** to prevent damage that may occur to exhibits, or property of others, or when necessary to move crates that may be in aisles.

Exhibitors may drive their motorized equipment in and out of the exhibit areas with **CSS** spotters, or have **CSS** supply an operator when available.

***Mobile units are to have 1/4 tank of gas or less and once vehicle is in place, battery is to be disconnected, gas cap locked or taped.***

#### EXHIBIT AREA:

MOBILE UNITS

\$ 250 PER UNIT (Round Trip)

Number of Units: \_\_\_\_\_ Type: \_\_\_\_\_

Dimensions of Largest Unit:

Height: \_\_\_\_\_ Width: \_\_\_\_\_ Length: \_\_\_\_\_ Weight: \_\_\_\_\_

Comments/Special Handling Requirements: \_\_\_\_\_

---



---



---

**PLEASE READ PAYMENT POLICY**

SUBTOTAL	\$
Tax Exempt	\$ -----
<b>TOTAL</b>	<b>\$</b>





1921 Bellamah NW  
 Albuquerque, NM 87104  
 t. 505.243.9889  
 f. 505.243.8197  
 www.cssabq.com

email us @  
 esr@cssabq.com

# RIGGING ORDER FORM

## CONVENTION SERVICES OF THE SOUTHWEST, INC.

Event Name: <b>SWTA 2024</b>	Advance Payment Deadline: <b>Monday, January 15, 2024</b>	Booth # (s):
Company Name:	Telephone #:	
Billing Address:	Fax #:	
City/State/Zip:	Email Address:	
Authorized by:		

**CSS** reserves the right to assemble, install, and dismantle hanging banners and signs (non-electrical) with approved devices and type of cable to safely hang banner or sign. **CSS** also reserves the right to use the required amount of labor to **safely** do the job.

Rigging labor will be billed in 1/2 hour increments with a **one-hour minimum**.

RATES FOR RIGGING	Advance Price	Standard Price
	Per Crew / Per Hour	Per Crew / Per Hour
Straight time – 8:00AM – 4:30PM (Weekdays)	\$557.00	\$669.00
Overtime – Before 8:00AM and after 4:30PM (Weekdays & Saturdays)	\$607.00	\$719.00
Sundays and Holidays	\$657.00	\$769.00

\*\*Exhibitor must contract all sign hanging with the official service contractor.

If banner or sign requires assembly, installation, and/or dismantling with the use of supporting devices such as cabling, wire, crosby's, and/or turnbuckles, work will be performed on a time and material basis. Materials will be invoiced at show site.

- ❖ **If riggers are not picked up or canceled without 24-hour notice, your estimated rigging hours will be charged.**
- ❖ **If display materials have not arrived by scheduled rigging install times, your estimated rigging hours will be charged.**

Does sign need to be assembled? **YES** **NO**

Please order sign assembly from "Labor Order Form".

Please complete this section:

	Date	Time	Approximate Hours	Estimated Cost
INSTALLATION				
DISMANTLE				

**SPECIAL INSTRUCTIONS: (Please provide information such as weight, size and shape of sign.)**

**PLEASE READ PAYMENT POLICY**

SUBTOTAL	\$ _____
Tax Exempt	\$ _____
<b>TOTAL</b>	<b>\$ _____</b>



1921 Bellamah NW  
Albuquerque, NM 87104  
t. 505.243.9889  
f. 505.243.8197  
www.cssabq.com

email us @  
esr@cssabq.com

## MATERIAL HANDLING INFORMATION & LIMITS OF LIABILITY

### CONVENTION SERVICES OF THE SOUTHWEST, INC.

#### MATERIAL HANDLING (DRAYAGE) INFORMATION

- ❖ As an exhibitor, you are responsible for providing your carrier with proper delivery and pickup information for your materials, both in advance and at show site.
- ❖ Please prepay all shipping charges. **CSS** cannot accept or be responsible for collect shipments. Keep in mind, **material handling** (drayage) charges and shipping charges are not the same thing.
  - “Drayage” is the movement of freight from decorator warehouse or show-site dock to exhibit booth and back out to the “freight carrier” at the show-site dock.
  - “Shipping” is movement of freight from city to city on a designated carrier.
- ❖ All shipments must be accompanied by a bill of lading. Shipments received without receipts, freight bills, or specified unit counts (UPS, Federal Express, personal vehicles, etc.) will be delivered to the exhibitor’s booth without guarantee of piece count or condition. No liability will be assumed by **CSS** for such shipments. Shipments without certified weight documents will be estimated by **CSS**. (*\*This estimate will be binding on both parties and no adjustments will be made after the show closes.*)
- ❖ **We will accept all cartons, crates, and skidded materials at the warehouse. Do not ship uncrated materials to the warehouse. Loose materials, uncrated materials, or machinery not banded to skids will be accepted at show site only.**
- ❖ **All van line shipments must be accompanied by a “certified weight ticket”, with heavy & light weights otherwise CSS will estimate freight weight, which will be binding on both parties and no adjustments will be made after the show closes.**
- ❖ All shipments for the show received either in advance or at show site will be assessed material handling charges by **CSS**. (*Please refer to the **Material Handling Rate Sheet**.*) All material handling rates are roundtrip and are based on incoming weights only. Overtime charges may apply under some circumstances, such as carrier-delayed freight delivered after designated move-in times.
- ❖ “Off-Target” freight is when freight arrives at the advance warehouse prior to the first scheduled day or after the last scheduled day indicated on both the show information sheet and the Material Handling Rate Sheet. If freight is delivered prior to the first scheduled day of advance freight receipt, storage charges may apply. If freight is delivered after the last scheduled day of advance freight receipt, additional delivery charges may apply.

#### **MATERIAL HANDLING INCLUDES:**

- Storing your booth, equipment, and materials in our warehouse for up to 30 days in advance of the show. (*Advance shipments only*)
- Delivering materials to your booth at show site.
- Removing empty containers from your booth, storing them for the duration of the show, then returning them to your booth at close of show.
- Moving packed and labeled materials from your booth to the dock area at close of show and reloading them on designated carriers based on information provided on your show site bill of lading (obtained from **CSS** Service Center).

#### **MATERIAL HANDLING DOES NOT INCLUDE:**

- Labor and/or equipment for uncrating, unskidding, assembling, positioning, leveling, dismantling, re-crating, and reskidding machinery and/or equipment for exhibitors. Additional labor to accomplish these tasks may be ordered from the **Labor Order Form** enclosed in the Exhibitor Service Kit.
- Scheduling any carrier for pick-up or delivery of your materials, if other than the official show carrier(s). All carriers must be checked in by the designated re-routing time or exhibitor freight will be either re-routed with show carrier or returned to **CSS** warehouse at exhibitor expense. Please refer to **Material Handling Rate Sheet** for re-route times.



1921 Bellamah NW  
Albuquerque, NM 87104  
t. 505.243.9889  
f. 505.243.8197  
www.cssabq.com

email us @  
esr@cssabq.com

## MATERIAL HANDLING INFORMATION & LIMITS OF LIABILITY

### CONVENTION SERVICES OF THE SOUTHWEST. INC.

#### LIMITS OF LIABILITY

##### **PLEASE READ:**

**CSS'** liability is limited to physical loss or damage to a specific article which is lost or damaged, and in any event **CSS'** maximum liability will be limited to \$.30 per pound, per article with a maximum liability of \$50.00 per item or \$1,000.00 per shipment, whichever is less.

**CSS** will not be liable to any extent whatsoever for any actual, potential, or assumed loss of profits or revenues, or for any collateral costs, which may result from any loss or damage to an exhibitor's materials which may make it impossible or impractical to exhibit said materials.

Claims for loss or damage that are not submitted to **CSS** within 30 days of the close of the show shall be considered waived.

The consignment or delivery of a shipment to **CSS** by an exhibitor, or by any shipper on behalf of the exhibitor, will be construed as an acceptance by such exhibitors (and/or shippers) of the terms and conditions set forth in this document.

To expedite removal of materials from the show site, **CSS** shall have the authority to change designated carriers, if such carriers do not pick-up on time. Where the exhibitor makes no disposition, materials will be either taken to a warehouse to await exhibitor's shipping instructions (in which case "return to the warehouse" charges will be incurred by exhibitor) or shipped to the exhibitor's address. Labeled shipments left in the facility at the close of the show without a bill of lading will be re-routed with the preferred carrier. No liability will be assumed as a result of such re-routing or handling.

**INSURE ALL SHIPMENTS FROM THE TIME THEY LEAVE YOUR COMPANY UNTIL THEY ARE RETURNED FROM THE SHOW.** Your present insurance carrier can add a rider to your current policy.

**IT IS THE RESPONSIBILITY OF THE EXHIBITOR TO MAKE ALL ARRANGEMENTS FOR PICK-UP AND DELIVERY OF FREIGHT. IF YOU CHOOSE TO USE OUR PREFERRED CARRIER, WE WILL MAKE ALL OUTBOUND ARRANGEMENTS FOR YOU. A COMPLETED BILL OF LADING WILL STILL BE REQUIRED.**

##### **CSS will not be responsible for:**

- Shipments delivered to the wrong booth due to improper labeling by the exhibitor.
- Misdirected shipments or removal of crates to storage due to old labels appearing on crates.
- Damage to uncrated or improperly packed materials, or concealed damage.
- Loss, theft, or disappearance of Exhibitor's material after it has been delivered to the exhibit booth.
- Loss, theft, or disappearance of Exhibitor's material prior to materials being picked up from exhibit booths for reloading after close of the show. **CSS** will check all bills of lading covering outgoing shipments at time of actual pick up from the exhibit booth. Corrections will be made to the bill of lading where discrepancies occur.
- Loss, damage, or delay due to fire, acts of God, strikes, lockouts, work stoppages of any kind, or any causes beyond **CSS** control.

**The exhibitor accepts the responsibility for the payment of charges in connection with the handling of the shipment and guarantees payment to CSS for the incurred services described herewith. SEE PAYMENT POLICY.**



1921 Bellamah NW  
Albuquerque, NM 87104  
t. 505.243.9889  
f. 505.243.8197  
www.cssabq.com

email us @  
esr@cssabq.com

# MATERIAL HANDLING AGREEMENT RATE SHEET AND ORDER FORM

## CONVENTION SERVICES OF THE SOUTHWEST, INC.

Event Name: <b>SWTA 2024</b>	Advance Payment Deadline: <b>Monday, January 15, 2024</b>	Booth # (s):
Company Name:	Telephone #:	
Billing Address:	Fax #:	
City/State/Zip:	Email Address:	
Authorized by:		

YOU ARE ENTERING A CONTRACT WHICH LIMITS YOUR POSSIBLE RECOVERY IN CASE OF LOSS OR DAMAGE. Acceptance of CSS' payment policy, material handling terms and conditions, and limits of liability will be construed when any of the following conditions are met: This Material Handling Agreement (MHA) is signed; Exhibitor's materials are delivered to CSS's warehouse or to an event site for which CSS is the Official Show Contractor; or an order for labor and/or rental equipment is placed by Exhibitor with CSS.

ADVANCE FREIGHT RECEIVING Monday – Friday 11:00AM – 4:00PM Tuesday, January 2 – Thursday, February 1, 2024 ADVANCE SHIPPING ADDRESS	
Ship To:	Exhibitor Name and Booth # SWTA 2024 c/o CSS ABF Freight 4410 S. Jackson Tulsa, OK 74107
Number of Pieces:	Estimated Weight:
Inbound Freight Carrier:	

FIRST DAY FOR DIRECT FREIGHT Sunday, February 4, 2024 --- 8:00AM – 5:00PM Monday, February 5, 2024 --- 8:00AM – 12:00PM DIRECT SHIPPING ADDRESS	
Ship To:	Exhibitor Name and Booth # c/o CSS SWTA 2024 Cox Business Convention Center – Exhibit Halls A&B 100 Civic Center Tulsa, OK 74103
Number of Pieces:	Estimated Weight:
Inbound Freight Carrier:	

**Our preferred freight carrier is: ArcBest (ABF Freight) 1-800-654-7019**

**\*\*Freight will be re-routed from show floor on Tuesday, February 6, 2024 @ 5:00PM\*\***

<b>SAMPLE:</b> Weight <u>500</u> ÷ 100 = Total CWT <u>5</u> @ <u>\$ 120</u> per cwt = <u>\$ 600</u>
-----------------------------------------------------------------------------------------------------

**ADVANCE FREIGHT RATES:** (includes crates, skidded, and carton materials)

\$ 120 per cwt. \$ 240 minimum charge  
Weight \_\_\_\_\_ ÷ 100 = Total CWT \_\_\_\_\_ @ \$ 120 per cwt = \$ \_\_\_\_\_

**DIRECT FREIGHT RATES:** (includes crates, skidded, and carton materials)

\$ 109 per cwt. \$ 218 minimum charge  
Weight \_\_\_\_\_ ÷ 100 = Total CWT \_\_\_\_\_ @ \$ 109 per cwt = \$ \_\_\_\_\_

**All charges are per hundred pounds (cwt) with a 200 lb. minimum per shipment. All shipments are rounded to the next hundred pounds.**

**ADDITIONAL RATES:**

“Late Shipments” and “Off Target” freight will be charged an **additional \$24 per cwt.** (200 lb. minimum applies)

“Small Package” or shipments weighing 30 lbs. or less will be charged a **\$67 material handling fee.**

**Banding and Shrink Wrap** will be charged at **\$78** per skid or crate.

**Outbound Material Handling Only** (freight handled at close of show only) will be charged **\$65 per cwt.** (200 lb. minimum applies)

**PLEASE READ PAYMENT POLICY**

SUBTOTAL	\$ _____
Tax Exempt	\$ -----
<b>TOTAL</b>	<b>\$ _____</b>

# ADVANCE WAREHOUSE SHIPPING LABELS



## ADVANCE WAREHOUSE

CONVENTION SERVICES OF THE SOUTHWEST, INC.

TO: \_\_\_\_\_

(Exhibiting Company Name)

BOOTH #: \_\_\_\_ NO. \_\_\_\_ of \_\_\_\_ PCS

**SWTA 2024**

**c/o CSS**

ABF Freight

4410 S. Jackson

Tulsa, OK 74107

Warehouse Hours: M-F - 11:00AM-4:00PM

**MUST ARRIVE BY:** Thurs., Feb. 1, 2024

**RUSH**



## ADVANCE WAREHOUSE

CONVENTION SERVICES OF THE SOUTHWEST, INC.

TO: \_\_\_\_\_

(Exhibiting Company Name)

BOOTH #: \_\_\_\_ NO. \_\_\_\_ of \_\_\_\_ PCS

**SWTA 2024**

**c/o CSS**

ABF Freight

4410 S. Jackson

Tulsa, OK 74107

Warehouse Hours: M-F - 11:00AM-4:00PM

**MUST ARRIVE BY:** Thurs., Feb. 1, 2024

**RUSH**

# DIRECT SHIPPING LABELS



## DIRECT TO SHOW

CONVENTION SERVICES OF THE SOUTHWEST, INC.

TO: \_\_\_\_\_

(Exhibiting Company Name)

BOOTH #: \_\_\_\_ NO. \_\_\_\_ of \_\_\_\_ PCS

**SWTA 2024**

**c/o CSS**

Cox Business CC – Exhibit Halls A&B

100 Civic Center

Tulsa, OK 74103

Must NOT arrive before 2/4/24

**DIRECT Shipments Received:**

Sun., Feb. 4, 2024 – 8:00AM – 5:00PM

Mon., Feb. 5, 2024 – 8:00 AM – 12:00 PM

**RUSH**



## DIRECT TO SHOW

CONVENTION SERVICES OF THE SOUTHWEST, INC.

TO: \_\_\_\_\_

(Exhibiting Company Name)

BOOTH #: \_\_\_\_ NO. \_\_\_\_ of \_\_\_\_ PCS

**SWTA 2024**

**c/o CSS**

Cox Business CC – Exhibit Halls A&B

100 Civic Center

Tulsa, OK 74103

Must NOT arrive before 2/4/24

**DIRECT Shipments Received:**

Sun., Feb. 4, 2024 – 8:00AM – 5:00PM

Mon., Feb. 5, 2024 – 8:00 AM – 12:00 PM

**RUSH**



1921 Bellamah NW  
 Albuquerque, NM 87104  
 t. 505.243.9889  
 f. 505.243.8197  
 www.cssabq.com

email us @  
 esr@cssabq.com

# OUTBOUND SHIPPING INFORMATION

## CONVENTION SERVICES OF THE SOUTHWEST, INC.

Event Name: <b>SWTA 2024</b>	Advance Payment Deadline: <b>Monday, January 15, 2024</b>	Booth # (s):
Company Name:	Telephone #:	
Billing Address:	Fax #:	
City/State/Zip:	Email Address:	
Authorized by:		

EVERY OUTBOUND SHIPMENT WILL REQUIRE A **CSS** BILL OF LADING AND LABELS. WE WOULD BE HAPPY TO PREPARE THESE FOR YOU IN ADVANCE AND WILL HAVE THEM AVAILABLE AT THE **CSS** SERVICE DESK FOR YOU TO REVIEW AND SIGN. TO TAKE ADVANTAGE OF THIS SERVICE, PLEASE COMPLETE AND RETURN THIS FORM.

*This form is required when labor is **CSS** supervised.*

**SHIPPING INFORMATION (IMPORTANT:** If your freight is forwarding to another show, be sure to include the show name and your booth number):

**FROM:** SHIPPER/EXHIBITOR NAME: \_\_\_\_\_  
 BILLING ADDRESS: \_\_\_\_\_  
 \_\_\_\_\_  
 CITY: \_\_\_\_\_ STATE: \_\_\_\_\_ ZIP: \_\_\_\_\_

**TO:** COMPANY NAME: \_\_\_\_\_  
 DELIVERY ADDRESS: \_\_\_\_\_  
 \_\_\_\_\_  
 CITY: \_\_\_\_\_ STATE: \_\_\_\_\_ ZIP: \_\_\_\_\_  
 PHONE#: \_\_\_\_\_ ATTN: \_\_\_\_\_  
 SPECIAL INSTRUCTIONS: \_\_\_\_\_  
 \_\_\_\_\_  
 \_\_\_\_\_

**METHOD OF SHIPMENT** Please specify your choice by checking the following:

- The preferred carrier, **ArcBest (ABF Freight)**, is authorized to ship show materials to the above address. *(Exhibitor must contact ABF directly for quotes if needed at 800-654-7019 or [tradeshowsupport@archb.com](mailto:tradeshowsupport@archb.com).)*
- The assigned carrier **PRE-SCHEDULED (by exhibitor)** to pick-up during show move-out is:  
*(Please note the Exhibitor is responsible for scheduling carriers other than CSS Logistics.)*
  - Common Carrier \_\_\_\_\_
  - Van Line \_\_\_\_\_
  - Air Freight \_\_\_\_\_

NUMBER OF DESIRED SHIPPING LABELS: \_\_\_\_\_ *(Fed Ex and UPS shipping labels are not available)*

- Once your shipment is packed and ready to be picked up, please return the BOL to the Exhibitor Services Center.
- Verify the piece count, weight, and that a signature is on the BOL prior to shipping out.
- Shipments without paperwork turned in will be shipped through Preferred Show Carrier at Exhibitor's expense.



# **Official Transportation Provider** *via the ABF Freight® Network*

**Let ArcBest® make your next trade show the easiest you have ever attended!**

We have over **100** years of experience in the freight industry and a dedicated Trade Show division with service through North America through the ABF Freight® network.

Choose guaranteed, expedited shipping solutions – air or ground – with special discounted rates for your inbound and outbound shipments.

For personalized quotes, please call

**800-654-7019**

## **Our Services Include:**

*Priority handling of your inbound and outbound shipments*

*Guaranteed expedited air and ground services*

*LTL Ground Transportation*

*International Transportation*

*Trust your important trade show shipment to the leader in exhibition transportation services.*

**ArcBest®**  
*More Than Logistics™*



# REQUEST FOR INFORMATION

## ArcBest® Trade Show Services

Exhibiting Company \_\_\_\_\_ Contact Name \_\_\_\_\_

Title \_\_\_\_\_ Email \_\_\_\_\_ Phone \_\_\_\_\_

### SHIPPER INFORMATION

Company \_\_\_\_\_

Address \_\_\_\_\_  
\_\_\_\_\_

City \_\_\_\_\_ State \_\_\_\_\_ Zip \_\_\_\_\_

Pickup Date/Time \_\_\_\_\_

### FREIGHT INFORMATION

Piece Count and Type \_\_\_\_\_

Total Weight \_\_\_\_\_

Dimensions (L) \_\_\_\_\_ (W) \_\_\_\_\_ (H) \_\_\_\_\_

SHIP TO: Warehouse  Show Site

Show Name \_\_\_\_\_

Booth No. \_\_\_\_\_

Contractor \_\_\_\_\_

Show Dates \_\_\_\_\_

Address \_\_\_\_\_

City \_\_\_\_\_ State \_\_\_\_\_ Zip \_\_\_\_\_

Delivery Date \_\_\_\_\_

### ADDITIONAL INFORMATION

Residential Pickup  Inside Pickup

Liftgate  Dock

Would you like an ArcBest Trade Show Coordinator to contact you with a quote or information?  YES  NO

If you are faxing this form, please print a copy, complete the requested information, and then fax to (844) 718-7620.

If you are completing electronically, you can either print and fax your request or click on the submit button to send your request to one of our Trade Show specialists.

**800-654-7019**

**tradeshow@arcb.com | arcb.com**

8401 McClure Drive • Fort Smith, AR • 72916





1921 Bellamah NW  
 Albuquerque, NM 87104  
 t. 505.243.9889  
 f. 505.243.8197  
 www.cssabq.com

email us @  
 esr@cssabq.com

# CLEANING ORDER FORM

## CONVENTION SERVICES OF THE SOUTHWEST, INC.

Event Name: <b>SWTA 2024</b>	Advance Payment Deadline: <b>Monday, January 15, 2024</b>	Booth # (s):
Company Name:	Telephone #:	
Billing Address:	Fax #:	
City/State/Zip:	Email Address:	
Authorized by:		

### CLEANING SERVICES (select only one of the services below)

SERVICES AVAILABLE		
Quantity (# of booths)	Description	Price
	<b>Initial Cleaning</b> (Vacuum & empty wastebasket(s) before first show day only)	\$ .54 per sq. ft. (One Day)
	<b>Daily Cleaning</b> (Vacuum & empty wastebasket(s) for all show days)	\$ .48 per sq. ft. (Daily)
	<b>Daily Porter Service</b> (Empty wastebasket(s) and periodic trash pick-up during show hours)	\$2.14 per sq. ft. (Daily)

### PLEASE COMPUTE COST BELOW.

(To compute booth size: Length x Width)

**NOTE: A MINIMUM OF 100 SQ. FT. WILL BE ASSESSED FOR TOTAL SQ. FT. AMOUNT.**

# of Booths	X	Booth Size	=	Total sq. ft.	X	Rate per sq. ft.	X	# of Days	=	Subtotal
_____	X	_____	=	_____	X	_____	X	_____	=	_____

**Companies who leave garbage in aisles or have excessive giveaway boxes will be mandated daily cleaning.**

Please bring any discrepancies regarding these services to our attention prior to show close. CSS is unable to adjust invoices after the close of the show.

### PLEASE READ PAYMENT POLICY

SUBTOTAL	\$
Tax (9.4%)	\$
<b>TOTAL</b>	<b>\$</b>



1921 Bellamah NW  
 Albuquerque, NM 87104  
 t. 505.243.9889  
 f. 505.243.8197  
 www.cssabq.com

email us @  
 esr@cssabq.com

## FLORAL ORDER FORM

### CONVENTION SERVICES OF THE SOUTHWEST, INC.

Event Name: <b>SWTA 2024</b>	Advance Payment Deadline: <b>Monday, January 15, 2024</b>	Booth # (s):
Company Name:	Telephone #:	
Billing Address:	Fax #:	
City/State/Zip:	Email Address:	
Authorized by:		

Quantity	Item	Advance Price	Standard Price	Total
	Floral Arrangement 12"H x 12"W	111	134	
	Floral Arrangement 18"H x 12"W	156	188	
	Custom Designed Arrangement Color: Height:                      Width:	<b>Contact for Quote</b>		
	Potted Flowers ( <i>please circle choice</i> ) Kalanchoe                      Persian Violet Azalea                              Chrysanthemum Begonia                              Cyclamen Seasonal	102	121	
	Mums ( <i>select color</i> ) White              Yellow              Purple              Rust	102	121	
	Small Ferns	64	77	
	Large Ferns	102	121	
	3 – 4 foot green plants	121	146	
	5 – 6 foot green plants	200	241	
	7 – 8 foot green plants	246	295	
		<b>Delivery Charge</b>		21
<b>PLEASE READ PAYMENT POLICY</b>		SUBTOTAL		\$
		Tax (9.4%)		\$
		<b>TOTAL</b>		<b>\$</b>

Plants remain the property of the subcontractor for **CSS**. There will be an **additional charge** for plants **not in the booth** at the conclusion of the event. Floral arrangements are the property of the exhibitor and may be removed from show site. **All flowering plants will be subject to availability.** Substitutes of equal quality may be made upon decision of the florist.

**Rental price includes** decorative container, top dressing, and professional maintenance. ALL ORDERS MUST BE PAID IN FULL AT THE TIME THE ORDER IS PLACED.



1921 Bellamah NW  
Albuquerque, NM 87104  
t. 505.243.9889  
f. 505.243.8197  
www.cssabq.com

email us @  
esr@cssabq.com

# SIGN/GRAPHICS ORDER FORM

## CONVENTION SERVICES OF THE SOUTHWEST, INC.

Event Name: <b>SWTA 2024</b>	Advance Payment Deadline: <b>Monday, January 15, 2024</b>	Booth # (s):
Company Name:	Telephone #:	
Billing Address:	Fax #:	
City/State/Zip:	Email Address:	
Authorized by:		

Fill out section below. Include copy & rough layouts on a separate piece of paper and mail or fax to us. Please circle orientation of signage.

Quantity	Size	Orientation	Letter Color	Advance Price	Standard Price	Total
	7" x 11"	Vertical Horizontal		21	26	
	7" x 44"	Vertical Horizontal		48	58	
	11" x 14"	Vertical Horizontal		60	68	
	14" x 22"	Vertical Horizontal		74	89	
	22" x 28"	Vertical Horizontal		100	120	
	24" x 36"	Vertical Horizontal		135	162	
	28" x 44"	Vertical Horizontal		188	227	
	Meter Board (1 meter x 8')	Vertical (unframed)		425	509	
	Custom Signs	Vertical Horizontal		<b>Contact for Quote</b>		
	Banners			<b>Contact for Quote</b>		

### PLEASE READ PAYMENT POLICY.

SUBTOTAL	\$
Tax (9.4%)	\$
<b>TOTAL</b>	<b>\$</b>

Orders placed within 48 hours of show start date will be charged at 150% of the standard price and may be subject to additional delivery or handling charges.

Note: Prices are based on DIGITAL OUTPUT mounted on Foam Core.  
If you prefer other materials such as Fabric, Komatex, Plexi Glass, Koraplast, and/or Gator Foam, they will be quoted upon request.

#### Guidelines for Submitting Artwork:

Artwork should be submitted through the FTP website (please contact us for detailed instructions) or via e-mail in a zip folder (limited to 10 MB per email). In order for us to use a graphic file it must be saved in one of the following file formats:

**VECTOR FILES: .AI, .EPS (Please change fonts to outline or include font types.)**  
**RASTER FILES: .PSD, .TIF, .EPS, .JPG**

When submitting a raster file, the **optimal resolution is 100 PPI** at 100% or **200 PPI** if file is built at 1/2 size. Lower resolution files will have a negative result on the image quality.

When submitting files, please include the following: Sign/Graphics Order Form, email address/originator of the artwork, printed color copy of the artwork, separations, and CMYK values.

#### PLEASE ATTACH SIGN COPY AND ANY SPECIAL INSTRUCTIONS:



1921 Bellamah NW  
Albuquerque, NM 87104  
t. 505.243.9889  
f. 505.243.8197  
www.cssabq.com

email us @  
esr@cssabq.com

## FIRE REGULATIONS

# CONVENTION SERVICES OF THE SOUTHWEST, INC.

### FIRE PREVENTION REGULATIONS

#### **PLEASE READ CAREFULLY AND COMPLETELY!**

**Aisles are not to be blocked unless it is clearly indicated on the Fire Marshal approved floor plan. Exits, exit signs, and firefighting equipment are not to be blocked or concealed from view in any manner.**

Fire inspections may be conducted during the course of move-in and move-out. A pre-opening inspection shall be conducted. Spot inspections may be conducted during the course of the show. The show will not be permitted to open without the approval of the Fire Marshal or his/her authorized representative.

If violations are found during the exhibit, booth(s) shall be subject to closure. Booth operators or employees may also be subject to a citation, which may result in up to a \$500.00 fine, 90 days in jail, or both.

Exhibit booths shall be constructed of non-combustible or limited-combustible materials.

Acoustical and decorative material including, but not limited to cotton, hay, paper, straw, moss, split bamboo, and wood chips shall be flame retardant treated to the satisfaction of the authority having jurisdiction. **Materials that cannot be treated for flame retardancy shall not be used.** Foamed plastics and materials containing foamed plastics used and decorative objects such as, but not limited to mannequins, murals, and signs shall have a maximum heat release rate for any single fuel package of 150 kW when tested in accordance with UL 1975, Standard for Fire Tests for Foamed Plastic used for Decorative Purposes.

**FIELD FLAME TEST:** Flame retardant materials shall not ignite and spread over the surface when exposed to open flame.

1. Oilcloth, tarpaper, nylon, plastic cloths, and certain other plastic materials cannot be made flame retardant and their use is prohibited.
2. Compressed flammable gases flammable/combustible liquids and hazardous chemicals are prohibited inside the building.
3. The use of LP-Gas cylinders is prohibited. **Exception:** Non-refillable cylinder may be used where permitted by the authority having jurisdiction. Compressed Gas **only** 12-16oz.
4. Hazardous chemicals and materials including pesticides, fungicides, insecticides, caustics, corrosives, oxidizers, flammable, poisons, and toxins are prohibited inside the building.
5. Combustible materials (i.e. crates and boxes) shall be limited to a one (1)-day supply and shall be maintained in an orderly fashion. **Storage of any combustible materials behind booths is prohibited.**

**SPECIAL REQUIREMENTS:** Vehicles on display within an exposition facility shall comply with the following:

1. All fuel tank openings shall be locked and sealed in an approved manner to prevent the escape of vapors.
2. Battery terminals shall be disconnected and taped off, using a non-metallic tape.
3. Fueling and defueling within the facility is prohibited.
4. Vehicles shall not be moved at any time during show hours.
5. Fuel Limit: Fuel tank shall not exceed one quarter of the tank's capacity or 5 gallons, whichever is less.
6. Vehicles, boats, and similar exhibited products having over 100 sq. ft. (9.3 sq. m.) of roofed area shall be provided with smoke detectors acceptable to the authority having jurisdiction.

**OPEN FLAME DEVICES:** Neither open flame devices nor pyrotechnic devices shall be used in any assembly occupancy. Cooking and/or warming devices that produce gas laden vapors shall be electric. Sterno may be used for warming trays. Cooking devices shall be approved by a recognized testing laboratory (i.e. UL, FMO).

1. Cooking and/or warming devices shall be isolated from the public, either placing the device a minimum of four (4) feet back from the front of the booth, or providing a barrier between the cooking and/or warming device and the public.
2. Individual cooking and/or warming devices shall not exceed 228" surface area.
3. The label surface holding the cooking and/or warming device(s) shall be of a non-combustible material.
4. A minimum of two (2) feet shall be kept between cooking devices.
5. Combustible materials shall be kept three (3) feet away from any cooking and/or warming device.
6. A 40 BC extinguisher and lid or an approved automatic extinguishing system shall be provided with any booth utilizing

cooking and/or warming devices.

7. Type K fire extinguishers shall be utilized with deep fat fryers or appliances emitting grease laden vapors.
8. Lids to one side, to put on cooking/warming devices.

**CANDLES AND OTHER OPEN-FLAME DEVICES:** The use of candles and other open-flame devices shall be in accordance with the following:

1. Class I and II liquids and liquefied petroleum gasses shall not be used.
2. Liquid or solid-fueled lighting devices containing more than 8 ounces must self-extinguish and not leak fuel at a rate of more than ¼ teaspoon per minute if tipped over.
3. The devise or holder shall be constructed to prevent the spilling of liquid fuel or wax at the rate of more than ¼ teaspoon per minute when the devise or holder is not in an upright position.
4. The device or holder shall be designed so that it will return to the upright position after being tilted to an angle of 45 degrees from vertical. EXCEPTION: Units that self-extinguish if tipped over and that do not spill fuel or wax at the rate of more than ¼ teaspoon per minute if tipped over.
5. The flame shall be enclosed except as follows: **a)** openings on the sides shall not be more than 3/8 inch in diameter; **b)** openings on the top and the distance to the top shall be such that a single layer of tissue paper placed on the top will not ignite in ten (10) seconds.
6. Chimneys shall be made of noncombustible materials. Such chimneys shall be securely attached to the open-flame device. EXCEPTION: The chimney need not be attached to any open-flame device that will self-extinguish if the device is tipped over.
7. Shades, if used, shall be made of noncombustible materials and securely attached to the open-flame device holder of chimney.
8. Candelabras with flame-lighted candles shall be securely fastened in place to prevent overturning and must be located away from occupants using the area and away from possible contact with drapes, curtains, or other combustibles.
9. When in the opinion of the Fire Marshall, adequate safeguards have been taken, hand-held flame lighted candles can be allowed. Hand-held candles shall not be passed from one person to another while ignited.

**FLAMING FOODS AND BEVERAGES:** Flaming Foods and Beverages shall be in accordance with the following:

1. Flammable liquids used in the preparation of flaming food and beverage shall be dispensed from a (1) once container or from a container not to exceed a one (1)-quart capacity and having a controlled pouring device that limits the flow to one (1) ounce.
2. Flaming foods or beverages shall be prepared only in the immediate vicinity of the table being served. Flaming food or beverages shall not be transported or carried while burning.
3. The person preparing or serving the flaming foods or beverages shall have a wet cloth towel immediately available for use in smothering the flames in the event of an emergency.
4. The serving of flaming foods or beverages shall be done in a safe manner and shall not create high flames.
5. The pouring, ladling, or spooning of flammable foods or beverages is restricted to a maximum height of eight (8) inches above the receiving receptacle.

**IN ALL CASES:**

1. All fuel containers shall be secured to prevent spillage when not in use.
2. Fuel canisters shall be safety sealed for storage.
3. Storage or refueling containers are not to exceed a maximum of 16 ounces.
4. The storage of **ANY** combustible behind booths is prohibited.
5. The pouring, ladling, or spooning of flammable liquid is restricted to a maximum height of 8 inches above the receiving receptacle.

No exhibition or show will be permitted to open without the approval of the Fire Marshal or his/her authorized representative. Fire inspections may be conducted during the course of move-in and tear down. A pre-opening inspection shall be conducted. Spot inspections may be conducted during the course of the show. If violations are found during the exhibition or show, violating booth(s) shall be subject to closure.

The Fire Marshal's Office understands that each exhibition, show, or event are different. Depending on the circumstances of the event additional items may need to be addressed. In these instances it will be necessary to follow IFC Section 2416.1 which states in part: When in the opinion of the Fire Marshal, it is essential for public safety in a place of assembly or any other place where people congregate, due to the number of persons, or the nature of the performance, exhibition, display, contest, or activity, the owner, agent, or lessee, shall employ two or more qualified persons from within the fire department. Qualified persons would be as necessary for the greatest life safety, i.e. firefighters, paramedics, full truck crews, etc.





1921 Bellamah NW  
Albuquerque, NM 87104  
t. 505.243.9889  
f. 505.243.8197  
www.cssabq.com

email us @  
esr@cssabq.com

## **BUS DETAILING**

# **CONVENTION SERVICES OF THE SOUTHWEST, INC.**

## **Vehicle Detailing & Wash:**

In the event of anticipated winter weather, SWTA has made arrangements with Tulsa Transit for exhibiting vehicles to use the agency's vehicle wash only for weather-related cleaning. We will have the services of a local detailing company on-site at the Cox Business Convention Center for vehicle move-in on February 4<sup>th</sup> and will update that information soon.





1921 Bellamah NW  
Albuquerque, NM 87104  
t. 505.243.9889  
f. 505.243.8197  
www.cssabq.com

email us @  
esr@cssabq.com

## SAFETY TIPS AND INFORMATION

# CONVENTION SERVICES OF THE SOUTHWEST, INC.

## Safety is very important for everyone working in the Exhibit Hall.

Convention Services of the Southwest, Inc (**CSS**) values safety throughout our organization and demonstrates it in the work we perform. By following the safety guidelines below, you will be doing your part in creating a safe work environment.

### SAFETY GUIDELINES

- Only authorized personnel and employees allowed, all others are prohibited during move-in and move-out.
- Be aware of your surroundings. You are in an active work area with changing conditions. Pay attention.
- All exhibitors and attendees enter at their own risk. Do not enter the dock/yard areas – these areas can be particularly dangerous.
- Stay clear of machinery. Look for obstacles, machinery, and equipment that are in use. Drivers of these vehicles or machines may not be able to see you.
- Never stand on furniture. These objects are not designed to support your standing weight.
- Prevent electrical shocks, falling items, and damage to materials. Do not attach items or equipment to the drapes or metal framework provided for your booth. This can cause serious injury or damage to materials.
- Wear closed toe shoes.
- Clean up or report spills.
- Practice good housekeeping. Keep aisles free and clear of any and all debris.
- Be aware of your surrounding areas for electrical cords or other trip hazards. Sometimes the view of equipment or items may be obstructed.
- Protect valuables at show site.
- Report any fires immediately.

If you notice anything unsafe, please contact a **CSS** employee immediately.

***During move-in and move-out unsupervised individuals under the age of 18 are prohibited from being on or around the show floor. Show sites during these times are similar to a construction zone and considered to be hazardous. OSHA regulations prohibit minors from being present in a hazardous work environment.***

### WORK ZONE

Customer acknowledges that the show site and surrounding areas are active work zones. Customer, its agents, employees and representative are present at their own risk.





1921 Bellamah NW  
Albuquerque, NM 87104  
t. 505.243.9889  
f. 505.243.8197  
www.cssabq.com

email us @  
esr@cssabq.com

**FACILITY SERVICES**  
Cox Business Convention Center - Tulsa

**CONVENTION SERVICES OF THE SOUTHWEST, INC.**

## **Cox Business Convention Center - Tulsa**

### **Ordering For:**

**IT SERVICES (Internet)**

**CATERING SERVICES**

**ELECTRICAL SERVICES**

**UTILITY SERVICES**

<https://exhibitors.venueops.com/exhibitorStore/account-1025/exhibition-1090-A>

# Exhibitor Services Policy Guide



**COX**  
BUSINESS  
CONVENTION  
CENTER

Cox Business Convention Center  
100 Civic Center, Tulsa, OK 74103  
(918) 894-4350  
[www.CoxCenterTulsa.com](http://www.CoxCenterTulsa.com)

All policies and rates contained in this guide are subject to changes without notice. Cox Business Convention Center's Event Policy Guide has been created to describe policies in conjunction with those in the event Use License Agreement. Any exceptions or circumstances not covered by the Exhibitor Policy Guide is subject to interpretation and approval by the Event Manager and Cox Business Convention Center's General Management team. This guide revised **September 2023** supersedes any policies and procedures prior to this date.



## Table of Contents

We are so excited to host your event at Cox Business Convention Center! To ensure your event goes smoothly from start to finish, we have put together this Exhibitor Policy Guide to provide a quick rundown of our policies and procedures, as well as provide you the information you need to begin planning.

Facility Information	3	Equipment/Utilities	6
Loading and Unloading Map	4	Deliveries & Freight	7
Getting Here	5	Drones & Unmanned Aerial Vehicles	7
Fly	5	Event Set Up	7
Ride	5	Lifts & Forklifts	8
Park	5	Lost and Found	8
Plan	5	Parking	8
Accessibility	6	Weapons	8
Animals	6	Permits	9
ATM	6	Smoking	9
Carpeting & Floors	6	Substances & Paraphernalia	9
Compressed Gas/Hazardous Materials	6	Trash Removal	9
Confetti, Streamers, & Glitter	6	Vehicle Displays	9



## Facility Information

Cox Business Convention Center is an award-winning venue in the arena district of downtown Tulsa, Oklahoma offering over 275,000 square feet of event space and 55,000 square feet in prefunction space. The facility is owned by the City of Tulsa and operated by ASM Global, a world leader in venue management.

### ADDRESS

100 Civic Center  
Tulsa, OK 74103

### EXHIBITOR SERVICES

CBC.C.Exhibitors@oakviewgroup.com  
918-406-5621

### COMMAND SECURITY

24 hours a day, 7 days a week  
(918) 894-4393

With ballrooms, exhibit halls, an assembly hall, a conference hall, and a multitude of meeting rooms available, we make it easy to design the perfect environment for any event or gathering at Cox Business Convention Center.

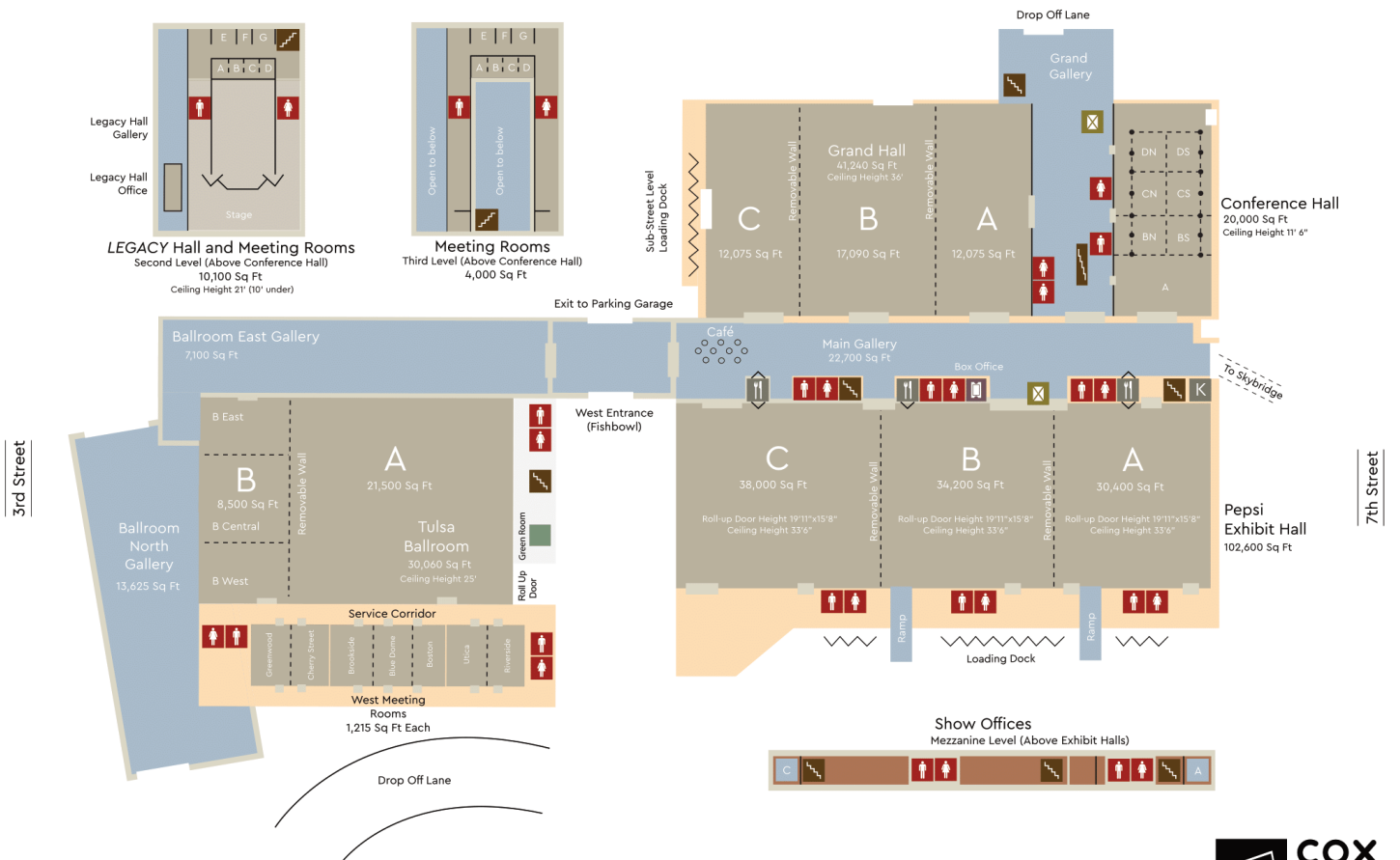

Online floor plans are available at <https://www.coxcentertulsa.com/event-resources/>. All dimensions and figures are approximate and may vary due to event production specifics and/or venue design developments.

Houston



Cox Business Convention Center  
100 Civic Center, Tulsa, OK 74103  
(918) 894-4350  
[www.CoxCenterTulsa.com](http://www.CoxCenterTulsa.com)





**Loading and Unloading Areas:**

- ◆ Exhibit Halls (RED)
- ◆ Tulsa Ballroom and West Meeting Rooms (BLUE)
- ◆ Grand Hall, Legacy Hall, Conference Hall (GREEN)

Cox Business Convention Center  
100 Civic Center, Tulsa, OK 74103  
(918) 894-4350  
www.CoxCenterTulsa.com





## PARK

There are nearly 10,000 parking spaces within a short walk of our facility:

- The City of Tulsa utilizes the Park Mobile app to pay for metered street parking downtown during business hours, and these parking spaces are free after 5:00pm each day
- The Civic Center Parkade located at 3rd and Houston Streets, which is owned and operated by American Parking, is connected to our facility by covered walkway; there are 1,395 spaces available in the Parkade and they are available for \$10-\$20 per car, per day depending on other downtown events
- There are several private lots which may open up for public parking during events at their own rates
- Parking attached to loading docks is first-come, first served. Clients have the right to reserve all designated spaces attached to their event space, so there is no guarantee on-site parking will be available.

## PLAN

Check for road closures and detours by visiting the [City of Tulsa Fix Our Streets website](#) or the [OK Department of Transportation website](#).





## Policies & Procedures

Cox Business Convention Center has the capability to service all of your event needs, ranging from large trade shows and exhibitions, to small meetings and conferences, to elegant banquets and galas. Some of the following policies and procedures apply to all of the events occurring at our facility, while others apply primarily to exhibit activities. Your Event Manager can assist if you have questions or would like further clarification regarding any of the following policies.

### ACCESSIBILITY

Cox Business Convention Center makes every effort to assist your needs and meets all requirements as stipulated by the Americans with Disabilities Act. If you have a disability and you need assistance, please contact our office at (918) 894.4350.

- **PARKING:** Patrons in need of accessible parking spaces may park in designated spots located in the Civic Center Parkade. The Parkade, owned and operated by American Parking, is located directly northeast of the facility and has a covered walkway connecting the two structures.
- **SENSORY NEEDS:** There is a sensory room available on the Legacy Hall Level. Ask for availability.
- **SERVICE ANIMALS:** Service animals are permitted inside Cox Business Convention Center.
- **WHEELCHAIRS:** Staff at Cox Business Convention Center can offer wheelchair service for guests who may need assistance. Please contact the Security Office at (918) 894-4393 for immediate assistance or arrange details in advance with your Event Manager. Wheelchair assistance is provided on a first-come, first-served basis due to the limited number of wheelchairs available. If wheelchair assistance is needed during an event, please notify the nearest staff member.

### ANIMALS

Service animals are permitted. Non-service animals are not allowed in Cox Business Convention Center at any time except with prior approval from Exhibitor Services for specific displays, exhibits, or performances.

### ATM

Guests can visit the Municipal Building or hotels adjacent to the facility for nearby ATM access.

### CARPETING & FLOORS

When installing carpeting in Cox Business Convention Center, your event decorator must first lay down painter's tape on hard floors, and gaff/carpet tape can then be used on top of the painter's tape. Because some carpet tape, duct tape, and other similar adhesives can damage facility surfaces when removed, we have tested various tapes and this proved the easiest and most cost-effective method. No tape may be used on carpeted floors in the facility.

### COMPRESSED GAS & HAZARDOUS MATERIAL

Compressed gas, such as a propane, brought on site must be approved in advance by Exhibitor Services. All compressed gas must be properly stored when on site; consult with Exhibitor Services to arrange storage. Hazardous material is not permitted to be used, stored, generated on, or transported to/from Cox Business Convention Center.

### CONFETTI, STREAMERS, & GLITTER

The use of confetti, streamers, glitter, and similar mess-making decorations or items at Cox Business Convention Center requires prior approval from your Event Manager. A \$1,000 clean-up fee will be required for use; level of labor required for clean-up can increase this fee.

### EQUIPMENT/UTILITIES

Cox Business Convention Center has an extensive list of rentable equipment and utilities for your event from tables and chairs to water access. All available items can be ordered and paid for at the provided exhibitor store for the event.



## DELIVERIES & FREIGHT

Cox Business Convention Center has limited warehousing or freight storage facilities on site. Freight and material handling should be organized through your event decorator.

## DRONES & UNMANNED AERIAL VEHICLES

The operator must provide a written, detailed description of the proposed drones or unmanned aerial vehicles (UAVs), including make, model number, manufacturer guidelines, and the proposed location, date, and time for the UAV operation. The operator will also be required to provide a certificate of liability insurance that covers the use of UAVs at Cox Business Convention Center in an amount not less than that required under the agreement. The certificate of insurance must stipulate the provider's coverage specifically amends the aircraft exclusion to allow for the type of UAV proposed to operate at on site and name the Indemnitees as additional insured. Satisfactory documentation must be provided to the Exhibitor Services Desk that the UAV operator has been trained and is qualified to operate the UAV. If approved by the Exhibitor Services Desk, the operator must ensure compliance at all times with any and all applicable laws, rules, regulations, and procedures issued by federal, state, and local governmental authorities or the operator of any airports or nearby sporting facilities, including without limitation the Federal Aviation Regulations and any rules and regulations issued by the FAA or the TSA as amended, modified, or supplemented from time to time. All UAV operators must secure final written approval from Cox Business Convention Center's Director of Event Services or Assistant General Manager before UAVs are operated in or near the facility or in connection with any event.

- **INDOOR UAV OPERATION:** Event attendees must be advised that UAVs will be used during the event, which must include posted signage at all entrances at the event's expense. UAVs are prohibited from flying over populated areas. UAVs are prohibited from being flown in prefunction spaces, meeting rooms, or other shared or public areas. UAVs must weigh less than 55 pounds. UAVs carrying weapons are prohibited. UAVs are prohibited from flying within 18" of any building structure, including sprinklers. UAVs must fly only in the defined event space or exhibit booth space as expressly approved by Cox Business Convention Center in accordance with the general conditions above. Attendees must be protected from UAVs using some form of netting, plastic, or other Cox Business Convention Center approved safety device. The event will incur the expense to have a member of Cox Business Convention Center Engineer escort the operator when UAV is in use in attendee populated spaces, and all parties must agree to abide by our Engineer's safety guidance.
- **OUTDOOR UAV OPERATION:** Valid permits including a Certificate of Waiver or Authorization (which are for public entities) or a Commercial Exemption or Special Airworthiness Certificate (for private entities) must be secured from the Federal Aviation Administration and provided to your Cox Business Convention Center Event Manager together with a representation and warranty that such Exemption or Certificate is valid. UAVs must be operated less than 400 feet above ground, away from airports and air traffic while also within sight of the operator, and comply with any temporary airspace restrictions as may be in place. Written approval must be secured from the City of Tulsa and provided to your Event Manager prior to your event.

## EVENT SET-UP

Per City Fire Code, no portion of any passageway or exit may be blocked or obstructed in any manner, no exit may be blocked



## LOADING & UNLOADING

Consult with Exhibitor Services to determine the availability of a loading area for your event and confirm. All event -related vehicles must be staged in designated portions of the service road or docks; those who are not may be towed. The following policies apply to all loading areas:

- Dock Marshals instructions must be followed while using a loading area to ensure safety and a smooth flow of traffic.
- Exhibitors and vendors arriving in personal vehicles will be given thirty minutes to load or unload their vehicle. Exhibitors should unload items at door, then immediately move vehicle to allow others to use the area. At that time the personal vehicle must be removed from the loading dock to ensure a smooth load-in experience for vendors and exhibitors loading and unloading. Once vehicle is parked you may move items to your booth.
- The facility may be hosting several events simultaneously, and we must maintain access to our loading docks and gallery entrances for all of our clients. Please do not block people in and do not block driving paths.
- An accessible fire lane must be present through loading areas at all times for to provide clearance for emergency vehicles.
- No carts or dollies are allowed through glass doors.

For the Exhibit Hall, trucks can load and unload at the West Loading Dock at 7th Street and Houston Avenue. Events loading or unloading for events in the Conference Hall or Legacy Hall may be able to utilize this dock, depending on availability. Vans, vehicles, and trailers have a 10 foot height limit. For the Tulsa Ballroom, trucks can load in the West Entrance street level loading area located centrally on the Houston Street side of the building. No trucks, lifts, or other devices besides dollies and push carts are allowed on the carpeted floors unless protected by plastic or plywood. For the Grand Hall, trucks can load in using the ramp located centrally on the east side and smaller loads can load through a set of 10' x 10' doors at street level by the Grand Gallery.

## LOST & FOUND

For lost and found inquiries, please call the Cox Business Convention Center Security Office at (918) 894-4393 during normal business hours.

## PARKING

Approximately 10,000 parking spots are located within a 10 minute walk of Cox Business Convention Center for you which includes metered street parking, the Civic Center Parkade operated by American Parking located to the northeast of the facility. Cox Business Convention Center does not operate or control any of the parking lots or services no located on our property. Pepsi Exhibit Hall, Tulsa Ballroom, Grand Hall events have a designated parking area and loading/unloading areas. Unless given express permission from the Event Client, exhibitors may not park in these areas. Exhibitors will be allowed to use the loading/unloading areas. Exhibitors should unload items at door, then immediately move vehicle to allow others to use the area. Once vehicle is parked you may move items to your booth.

## WEAPONS

By law, firearms are not permitted on Cox Business Convention Center property. Events, exhibitors, vendors, and event attendees should not bring weapons or ammunition of any kind, including cosplay and/or props, on premise without express written permission from the Client, Event Manager, and Exhibitor Services. Approved weapons may require onsite weapon checks and additional security measures.



## PERMITS

You are responsible for obtaining any permits or additional licenses that may be required by the federal, state, county, or city governments. Exhibitor Services can help you with any of the following permits or licenses required for your specific type of event:

- **FOOD AND BEVERAGE PERMIT:** This permit is required by The City of Tulsa if you will be selling food and/or beverages at your event. You can apply for the sales tax permit electronically by completing and filling out the Business Registration form online at <http://www.tax.ok.gov/busregonline.html>. Events planning to distribute food/beverages must obtain approval from **OVG Hospitality** prior to the event. Please consult with Exhibitor Services to request approval to distribute/sell food or beverages.

## ADDITIONAL POLICIES

- Cox Business Convention Center will only allow tape that has prior approval and is known to not cause damage. See the Carpeting & Floors section of this guide for approved adhesive. Nothing may be taped, nailed, stapled, tacked, or otherwise affixed to ceilings, painted surfaces, fire sprinklers, columns, fabric, decorative walls, or podiums throughout the facility.
- Work with Exhibitor Services on an installation plan for signage, banners, clings, and other displays.
- Cox Business Convention Center does not allow helium balloons and decals/stickers with an adhesive back in the facility. Exhibitor Services can work with you on acceptable alternatives.
- No advertising, painting, posting, or exhibiting is allowed inside, outside, or on any part of the facility without express permission from Exhibitor Services.
- All decorative materials must be flameproof in accordance with Fire Marshal rules and regulations, which includes drapes, banners, fabrics, posters, boards, signs, curtains, drops, trees, foliage, screens, plastics, and other decorative materials. Leave the flame retardant labels on any items sprayed or treated, such as drapes, holiday trees, etc. The Fire Marshal has the right to ask you to prove the products are safe and, without such proof, you may be asked to remove all items.

## SMOKING

- The City of Tulsa has a nonsmoking policy in all public and city-owned facilities, which includes Cox Business Convention Center, in the interest of public health, recognizing the medical evidence of the potential health hazards of secondhand smoke. No smoking of any kind, including vaping, e-cigarettes, or other devices, is allowed inside Cox Business Convention Center. There are designated smoking areas available outside of the facility.

## SUBSTANCES & PARAPHERNALIA

Cox Business Convention Center maintains a substance-free environment for our clients, guests, and patrons. The possession or use of THC products and/or illegal substances is strictly prohibited on the premise. No plants of any kind will be permitted on Cox Business Convention Center property. Devices which are used for the consumption of medical marijuana is permitted to be sold, distributed, and possessed on the premise. Any violations of this policy are subject to ejection and/or trespassing from the facility. Please contact your Event Manager for more information.

## TRASH REMOVAL

Basic trash removal services are provided complimentary on site at Cox Business Convention Center. If there is a substantial amount of trash that needs to be removed, please connect with Exhibitor Services for removal. A fee may be applied for excessive trash removal.

## VEHICLE DISPLAY

If you wish to have a motor vehicle such as a car or motorcycle as a display element for your booth, you must have an advance written permission from the Cox Business Convention Center Exhibitor Services Department. The Tulsa Fire Marshal has very specific rules and regulations regarding motor vehicles for display. Exhibitor Services can provide you with a copy of the Vehicle Display Waiver and the requirements to display a vehicle in the facility. Any vehicles which do not meet these requirements and display a countersigned copy of this waiver will be prohibited from displaying in the facility. Additionally, if vehicles are to be displayed in a carpeted space, their tires must be wrapped in plastic, and plywood must be placed over floor pockets before they can be driven into the facility. Contact Exhibitor Services for additional information and approval on display vehicles.

Cox Business Convention Center  
100 Civic Center, Tulsa, OK 74103  
(918) 894-4350  
[www.CoxCenterTulsa.com](http://www.CoxCenterTulsa.com)



## VEHICLE DISPLAY WAIVER

If you wish to have a motor vehicle, such as a car or motorcycle, on display inside of Cox Business Convention Center, you must have approval from the contract signee for the event and Cox Business Convention Center Event Manager. A completed version of this form must be given to the Event Manager on site at the time of vehicle load in. The vehicle will be prohibited from remaining inside as a display vehicle until all below requirements have been met and this form has been countersigned by an authorized representative of Cox Business Convention Center.

The City of Tulsa Fire Marshal has very specific rules and regulations regarding motor vehicles for display. **By signing this form, you are agreeing that the following rules will be strictly observed:**

- Fuel tank openings shall be locked or sealed in an approved manner to prevent escape of vapors.
- Fuel tanks shall not contain in excess of one-quarter their capacity or contain in excess of 19L (five gallons) of fuel, whichever is less.
- At least one battery cable shall be removed from the batteries used to start the vehicle engine, and the disconnected battery cable shall then be taped.
- No battery charging is permitted inside the building.
- External chargers or batteries are recommended for display purposes.
- Fueling or de-fueling of vehicles is prohibited.
- Combustible / flammable materials must not be stored beneath display vehicles.
- 36" wide space must be maintained around the display vehicle.
- 72" wide space must be maintained between vehicles displayed together.
- Vehicles shall not be moved during display hours.
- Visqueen must be laid under the vehicle and must remain under the vehicle during the time it is being displayed.
- Ignition keys must be removed from vehicle & keys/fob must be given to the Event Manager to be kept in the CBCC Security Office until the event is complete.

**Event Name:** \_\_\_\_\_

**Organization Name:** \_\_\_\_\_

**Vehicle Make, Model, & Year:** \_\_\_\_\_ **License Plate #:** \_\_\_\_\_

**Vehicle Contact Name:** \_\_\_\_\_

**Phone Number:** \_\_\_\_\_

**Email:** \_\_\_\_\_

**Vehicle Contact Signature:** \_\_\_\_\_ **Date:** \_\_\_\_\_

### REQUIREMENTS FULFILLED CONFIRMED BY:

**Cox Business Convention Center:** \_\_\_\_\_ **Date:** \_\_\_\_\_

**\*\*\* This countersigned form MUST be displayed prominently in the windshield or otherwise on the vehicle \*\*\***





# 2024 Exhibitor Order Form

SWTA Conference | Cox Convention Center



---

## Visual Axis AV

PO Box 656 Vian, OK 74962 | Phone: 501.626.8817 Voice/Text | E-mail: [visualaxisav@gmail.com](mailto:visualaxisav@gmail.com)

**We at Visual Axis AV are proud to offer a wide range of technology to enhance and attract attendees to your booth or exhibit. Allow us to help you stand out from the crowd!**

**Examples of equipment we offer include but are not limited to:**

**TV Monitors (Floor mount or table mount)**

**Computers**

**LED Up lighting**

**Sound systems**

**Projection**

**Special effects**

**...and more**

**Please contact us for availability and to schedule your equipment needs.**

**[visualaxisav@gmail.com](mailto:visualaxisav@gmail.com)**